

YU-TH18

AMERICA

BEST VALUE IN THE WORLD OF CUTTING TOOLS



TOOLING SYSTEM



- Hydraulic Chuck
- Shrink Fit Holder
- End Mill Holder & Side Lock Arbor
- ER Collet Chuck
- SK Slim Chuck
- TG Collet Chuck
- Power Milling Chuck
- Morse Taper Adapter
- Tapping Chuck
- Shell Mill Arbor
- NC Drill Chuck
- Jacobs Taper Arbor
- Stub Arbor
- Slitting Saw Arbor
- Pull Stud & Tool Clamp

YG TOOLING SYSTEM



NEW

**HYDRAULIC CHUCK
(POWER E HYDRO)**
ASME B5.50-2009-CAT



NEW

**SHRINK FIT HOLDER
(COOLANT CHANNEL TYPE)**
ASME B5.50-2009-CAT



**END MILL HOLDER
(COOLANT CHANNEL TYPE)**
ASME B5.50-2009-CAT



**DUAL CONTACT
ER COLLET CHUCK**
DIN 69893/ISO 12164-1-HSK FORM A



**SK SLIM
CHUCK**
ASME B5.50-2009- CAT



**DUAL CONTACT HIGH SPEED
POWER MILLING CHUCK**
DIN 69893/ISO 12164-1-HSK FORM A



**SYNCHRO TAPPING
ER CHUCK**
ASME B5.50-2009-CAT



**SHELL MILL
ARBOR**
ASME B5.50-2009-CAT



**NC DRILL
CHUCK**
ASME B5.50-2009-CAT

YG-1 manufactures and supplies wide variety of Quality Tool Holders to the customer, and the customer may choose the most suitable tool holder according to the customer's specific machining application in every industry.

The customer must enjoy not only the best competitiveness of YG-1 Tool Holder in Quality and Price, but also the most desirable one-stop tooling solution through YG-1 Tool Holder and YG-1 Cutting Tool provided by global sales network of YG-1.

YG-1, as a global leader in the manufacture and application of cutting tools, brings you these innovations worldwide in the form of superior tooling, expert support and world class delivery.

ROTARY TOOLING PRODUCT INDEX



HYDRAULIC CHUCK	HYDRAULIC CHUCK	
	• CAT	6
	• BT	12
	DUAL CONTACT HYDRAULIC CHUCK	
	• CCT	18
	• CBT	21
	• HSK	24
	HYDRAULIC CHUCK COLLET (REDUCTION SLEEVE)	29
SHRINK FIT HOLDER	SHRINK FIT HOLDER	
	• CAT	38
	• BT	40
	DUAL CONTACT SHRINK FIT HOLDER	
	• CCT	42
	• CBT	44
	• HSK	46
	SHRINK FIT EXTENSION	
	• ST	48
END MILL HOLDER & SIDE LOCK ARBOR	END MILL HOLDER	
	• CAT	52
	• BT	58
	DUAL CONTACT SIDE LOCK ARBOR	
	• CCT	63
	• CBT	64
	DUAL CONTACT END MILL HOLDER	
	• HSK (COOLANT CHANNEL TYPE)	65
ER COLLET CHUCK	ER COLLET CHUCK	
	• CAT	68
	• BT	70
	DUAL CONTACT ER COLLET CHUCK	
	• HSK	73
	SHORT & TENSION ER COLLET CHUCK	
	• SHORT	74
• TENSION (For TAPPING)	74	
	NC ER COLLET CHUCK	
	• NC (For CNC LATHE)	75
	ACCESSORY & PART	76
SK SLIM CHUCK	DUAL CONTACT SK SLIM CHUCK	
	• CAT	88
	• CCT	89
	• CBT	90
	• HSK	91
	STRAIGHT SK SLIM CHUCK	
• STRAIGHT-K	92	
	ACCESSORY & PART	93
TG COLLET CHUCK	TG COLLET CHUCK	
	• CAT	98
	• BT	99
	ACCESSORY & PART	100

ROTARY TOOLING PRODUCT INDEX



POWER MILLING CHUCK	POWER MILLING CHUCK	
	• CAT	102
	• BT	102
	DUAL CONTACT HIGH SPEED POWER MILLING CHUCK	103
	• CCT	103
	• CBT	104
	• HSK	105
	ACCESSORY & PART	106
MORSE TAPER ADAPTER	MORSE TAPER ADAPTER	
	• CAT	108
	• BT	108
TAPPING CHUCK	TAPPING CHUCK	
	• CAT	110
	• BT	111
	SYNCHRO TAPPING ER CHUCK	
	• CAT	112
	ACCESSORY & PART	113
SHELL MILL ARBOR	SHELL MILL ARBOR	
	• CAT	116
	• BT	117
	DUAL CONTACT SHELL MILL ARBOR	
	• CCT	118
	• CBT	119
	ACCESSORY & PART	120
NC DRILL CHUCK	NC DRILL CHUCK	
	• CAT	122
	• BT	123
	DUAL CONTACT NC DRILL CHUCK	
	• HSK	124
	STRAIGHT NC DRILL CHUCK	
	• STRAIGHT-K	124
JACOBS TAPER ARBOR	JACOBS TAPER ARBOR	
	• CAT	126
	• BT	126
STUB ARBOR	STUB ARBOR	
	• CAT	128
	• BT	128
SLITTING SAW ARBOR	SLITTING SAW ARBOR	
	• CAT	132
	• BT	132
PULL STUD & TOOL CLAMP	PULL STUD	134
	TOOL CLAMP	135
	COOLNT TUBE	135



ROTARY TOOLING

HYDRAULIC CHUCK



HYDRAULIC CHUCK

CAT : ASME B5.50-2009

- SLIM / POWER E HYDRO / SHORT & RIGID / RADIAL TOOL LENGTH PRE-SETTING TYPE / FOR MOULD

BT : JIS B6339/MAS 403

- SLIM / POWER E HYDRO / SHORT & RIGID / RADIAL TOOL LENGTH PRE-SETTING TYPE / FOR MOULD

DUAL CONTACT HYDRAULIC CHUCK

CCT : CAT DUAL CONTACT

- SLIM / POWER E HYDRO / FOR MOULD

CBT : BT DUAL CONTACT

- SLIM / POWER E HYDRO / FOR MOULD

HSK : DIN 69893/ISO 12164-1

- SLIM / POWER E HYDRO / SHORT & RIGID / RADIAL TOOL LENGTH PRE-SETTING TYPE / FOR MOULD

HYDRAULIC CHUCK COLLET

- REDUCTION SLEEVE : OPEN TYPE / CLOSED TYPE

HYDRAULIC CHUCK (SLIM)

CAT

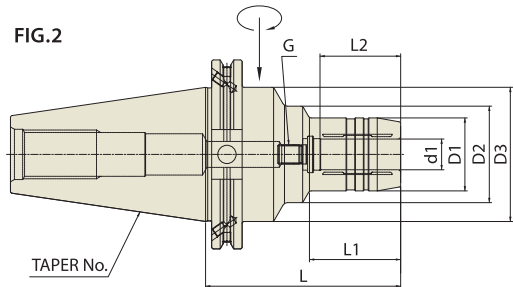
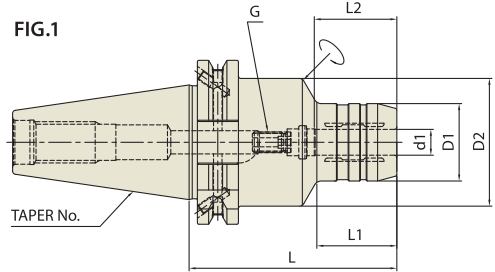

ASME B5.50 - CAT	Taper Accuracy AT3	G Value 2.5	RPM 25,000	Run-Out (at 3D) ≤0.00012"	Coolant System AD/B
------------------	------------------------------	-----------------------	----------------------	-------------------------------------	-------------------------------

ASME B5.50-2009-CAT

Unit: inch

EDP No.	TAPER No.	MODEL No.	d1	D1	D2	D3	L	L1	L2	G	Remarks
WK020	40	CAT40AD/B-HC1/4-4.00	0.250	1.024	1.750	-	4.000	1.280	1.063	M5x0.8mm	FIG.1
WK022		CAT40AD/B-HC3/8-4.00	0.375	1.181	1.750	-	4.000	1.634	1.260	M6x1.0mm	
WK024		CAT40AD/B-HC1/2-4.00	0.500	1.260	1.750	-	4.000	1.634	1.457	M10x1.0mm	
WK026		CAT40AD/B-HC5/8-4.00	0.625	1.496	1.750	-	4.000	1.949	1.654	M10x1.0mm	
WK028		CAT40AD/B-HC3/4-4.00	0.750	1.654	1.750	-	4.000	1.949	1.654	M10x1.0mm	
WK030		CAT40AD/B-HC1"-4.00	1.000	2.165	2.480	-	4.000	2.618	1.890	M16x1.0mm	
WK032		CAT40AD/B-HC1 1/4-4.00	1.250	2.480	3.150	-	4.000	1.378	2.165	M16x1.0mm	
WL020	50	CAT50AD/B-HC1/4-4.00	0.250	1.024	1.978	2.752	4.000	1.280	1.063	M5x0.8mm	FIG.2
WL022		CAT50AD/B-HC3/8-4.00	0.375	1.181	1.978	2.752	4.000	1.417	1.260	M6x1.0mm	
WL024		CAT50AD/B-HC1/2-4.00	0.500	1.260	1.978	2.752	4.000	1.634	1.457	M10x1.0mm	
WL026		CAT50AD/B-HC5/8-4.00	0.625	1.496	1.978	2.752	4.000	1.870	1.654	M10x1.0mm	
WL028		CAT50AD/B-HC3/4-4.00	0.750	1.654	1.978	2.752	4.000	1.949	1.654	M10x1.0mm	
WL030		CAT50AD/B-HC1"-4.00	1.000	2.244	2.480	2.752	4.000	1.949	1.890	M16x1.0mm	
WL032		CAT50AD/B-HC1 1/4-4.00	1.250	2.520	-	2.752	4.000	2.559	2.165	M16x1.0mm	

* Applicable Hydraulic Chuck collets(reduction sleeves) on page 29~36.

HYDRAULIC CHUCK (SLIM)

CAT

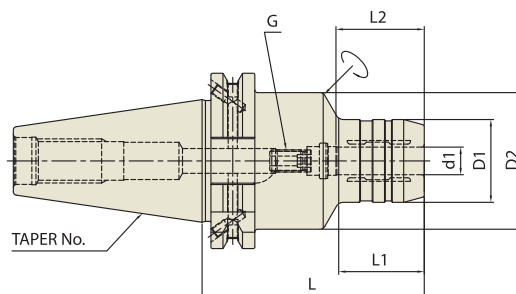

ASME B5.50 - CAT	Taper Accuracy AT3	G Value 2.5	RPM 25,000	Run-Out (at 3D) ≤0.00012"	Coolant System AD/B
------------------	------------------------------	-----------------------	----------------------	-------------------------------------	-------------------------------

ASME B5.50-2009-CAT

Unit : mm

EDP No.	TAPER No.	MODEL No.	d1	D1	D2	L	L1	L2	G
WK060	40	CAT40AD/B-HC6-80.5	6	26	49.5	80.5	29.5	27	M5x0.8
WK062		CAT40AD/B-HC6-110	6	26	49.5	110	29.5	27	M5x0.8
WK064		CAT40AD/B-HC8-80.5	8	28	49.5	80.5	30	27	M6x1.0
WK066		CAT40AD/B-HC8-110	8	28	49.5	110	30	27	M6x1.0
WK068		CAT40AD/B-HC10-80.5	10	30	49.5	80.5	31	32	M8x1.0
WK070		CAT40AD/B-HC10-110	10	30	49.5	110	31	32	M8x1.0
WK072		CAT40AD/B-HC12-80.5	12	32	49.5	80.5	31.5	37	M10x1.0
WK074		CAT40AD/B-HC12-110	12	32	49.5	110	31.5	37	M10x1.0
WK076		CAT40AD/B-HC16-80.5	16	38	49.5	80.5	33	42	M12x1.0
WK078		CAT40AD/B-HC16-110	16	38	49.5	110	33	42	M12x1.0
WK080		CAT40AD/B-HC20-80.5	20	42	49.5	80.5	34	42	M16x1.0
WK082		CAT40AD/B-HC20-110	20	42	49.5	110	34	42	M16x1.0
WK084		CAT40AD/B-HC25-80.5	25	55	66	80.5	22	48	M16x1.
WK086		CAT40AD/B-HC32-80.5	32	63	80	80.5	25.5	55	M16x1.0
WL060	50	CAT50AD/B-HC6-80.5	6	26	49.5	80.5	30	27	M5x0.8
WL062		CAT50AD/B-HC8-80.5	8	28	49.5	80.5	30	27	M6x1.0
WL064		CAT50AD/B-HC10-80.5	10	30	49.5	80.5	32	32	M8x1.0
WL066		CAT50AD/B-HC12-80.5	12	32	49.5	80.5	35	37	M10x1.0
WL068		CAT50AD/B-HC16-80.5	16	38	49.5	80.5	40	42	M12x1.0
WL070		CAT50AD/B-HC20-80.5	20	42	49.5	80.5	40	42	M16x1.0

* Applicable Hydraulic Chuck collets(reduction sleeves) on page 29~36.

HYDRAULIC CHUCK (Power E Hydro) **NEW**

CAT

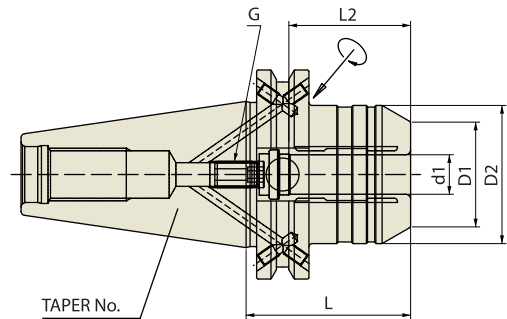

ASME B5.50 - CAT	Taper Accuracy AT3	G Value 2.5	RPM 25,000	Run-Out (at 3D) ≤0.00012"	Coolant System AD/B
-------------------------	------------------------------	-----------------------	----------------------	-------------------------------------	-------------------------------

ASME B5.50-2009-CAT

Unit : inch

EDP No.	TAPER No.	MODEL No.	d1	D1	D2	L	L2	G
WK022PE	40	CAT40AD/B-HC3/4P-2.539	0.75	1.496	1.938	2.539	1.889	M8x1.0mm
WK023PE		CAT40AD/B-HC3/4P-4.000	0.75	1.496	1.938	4.000	1.889	M8x1.0mm
WL028PE	50	CAT50AD/B-HC1 1/4P-3.188	1.25	2.303	2.834	3.188	2.244	M8x1.0mm
WL030PE		CAT50AD/B-HC1 1/4P-6.000	1.25	2.303	2.834	6.000	2.244	M8x1.0mm

Unit : mm

EDP No.	TAPER No.	MODEL No.	d1	D1	D2	L	L2	G
WK102PE	40	CAT40AD/B-HC20P-64.5	20	38	49.25	64.5	48	M8x1.0
WK103PE		CAT40AD/B-HC20P-101.6	20	38	49.25	101.6	48	M8x1.0
WL104PE	50	CAT50AD/B-HC32P-81	32	58.5	72	81	57	M8x1.0
WL106PE		CAT50AD/B-HC32P-152.4	32	58.5	72	152.4	57	M8x1.0

- * High Clamping Torque Power version
(Please refer to page 137, Technical Information)
- * Applicable for milling(roughing and finishing)
- * Applicable Hydraulic Chuck collets(reduction sleeves) on page 29~36.

HYDRAULIC CHUCK (SHORT & RIGID)

CAT

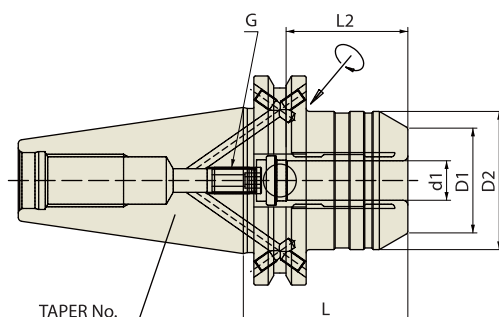

ASME B5.50 - CAT	Taper Accuracy AT3	G Value 2.5	RPM 25,000	Run-Out (at 3D) ≤0.00012"	Coolant System AD/B
-------------------------	------------------------------	-----------------------	----------------------	-------------------------------------	-------------------------------

ASME B5.50-2009-CAT

Unit : inch

EDP No.	TAPER No.	MODEL No.	d1	D1	D2	L	L2	G
WK020SNR	40	CAT40AD/B-HC1/2S-2.52	0.500	1.260	1.654	2.520	1.457	M8x1.0mm
WK021SNR		CAT40AD/B-HC5/8S-2.52	0.625	1.362	1.752	2.520	1.654	M10x1.0mm
WK022SNR		CAT40AD/B-HC3/4S-2.52	0.750	1.469	1.949	2.520	1.654	M10x1.0mm
WK024SNR		CAT40AD/B-HC1S-3.50	1.000	2.244	2.598	3.500	1.890	M16x1.0mm
WL020SNR	50	CAT50AD/B-HC1/2S-3.19	0.500	1.879	2.752	3.189	1.457	M8x1.0mm
WL022SNR		CAT50AD/B-HC5/8S-3.19	0.625	1.819	2.752	3.189	1.654	M8x1.0mm
WL024SNR		CAT50AD/B-HC3/4S-3.19	0.75	2.185	2.752	3.189	1.654	M10x1.0mm
WL026SNR		CAT50AD/B-HC1.00S-3.19	1.000	2.185	2.752	3.189	1.890	M16x1.0mm
WL028SNR		CAT50AD/B-HC1.25S-3.19	1.250	2.185	2.752	3.189	2.165	M16x1.0mm

Unit : mm

EDP No.	TAPER No.	MODEL No.	d1	D1	D2	L	L2	G
WK100SNR	40	CAT40AD/B-HC12S-50	12	32	42	50	37	M8x1.0
WK102SNR		CAT40AD/B-HC20S-64.5	20	37	49.5	64.5	42	M16x1.0
WL100SNR	50	CAT50AD/B-HC12S-50	12	32	42	50	37	M8x1.0
WL102SNR		CAT50AD/B-HC20S-64.5	20	37	49.5	64.5	42	M16x1.0
WL104SNR		CAT50AD/B-HC32S-81	32	55	72	81	55	M16x1.0

* Applicable Hydraulic Chuck collets(reduction sleeves) on page 29~36.

HYDRAULIC CHUCK (RADIAL TOOL LENGTH PRE-SETTING TYPE)

CAT

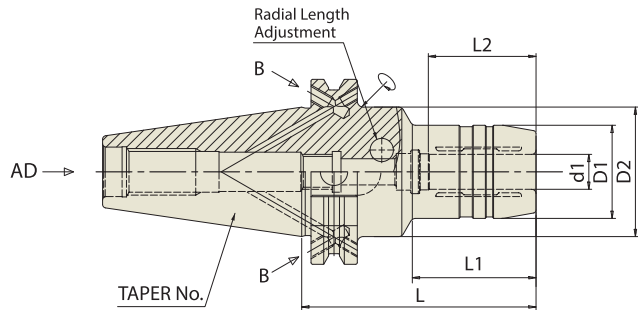

ASME B5.50 - CAT	Taper Accuracy AT3	G Value 2.5	RPM 25,000	Run-Out (at 3D) ≤0.00012"	Coolant System AD/B
------------------	------------------------------	-----------------------	----------------------	-------------------------------------	-------------------------------

ASME B5.50-2009-CAT

Unit : mm

EDP No.	TAPER No.	MODEL No.	d1	D1	D2	L	L1	L2
WK100HCR	40	CAT40AD/B-HCR12-80.5	12	32	49.5	80.5	31.5	37
WK102HCR		CAT40AD/B-HCR20-80.5	20	42	49.5	80.5	34	42
WK104HCR		CAT40AD/B-HCR32-110	32	64	80	110	50	55
WL100HCR	50	CAT50AD/B-HCR12-80.5	12	32	49.5	80.5	31.5	37
WL102HCR		CAT50AD/B-HCR20-80.5	20	42	49.5	80.5	34	42
WL104HCR		CAT50AD/B-HCR32-100	32	60	60	100	-	55

* Applicable Hydraulic Chuck collets(reduction sleeves) on page 29~36.

HYDRAULIC CHUCK (For MOULD)

CAT

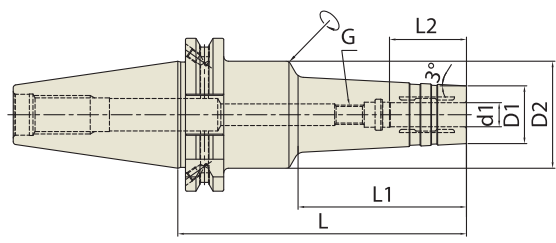

ASME B5.50 - CAT	Taper Accuracy AT3	G Value 2.5	RPM 25,000	Run-Out (at 3D) ≤0.00012"	Coolant System AD/B
-------------------------	------------------------------	-----------------------	----------------------	-------------------------------------	-------------------------------

ASME B5.50-2009-CAT

Unit : inch

EDP No.	TAPER No.	MODEL No.	d1	D1	D2	L	L1	L2	G	
WK020HMC	40	CAT40AD/B-HMC1/4-4.72	0.250	0.787	1.949	4.724	2.756	1.063	M5x0.8mm	
WK022HMC		CAT40AD/B-HMC1/4-5.91	0.250	0.787	1.949	5.906	3.937	1.063	M5x0.8mm	
WK024HMC		CAT40AD/B-HMC5/16-4.72	0.313	0.866	1.949	4.724	2.756	1.063	M6x1.0mm	
WK026HMC		CAT40AD/B-HMC5/16-5.91	0.313	0.866	1.949	5.906	3.937	1.063	M6x1.0mm	
WK028HMC		CAT40AD/B-HMC3/8-4.72	0.375	0.945	1.949	4.724	2.756	1.260	M8x1.0mm	
WK030HMC		CAT40AD/B-HMC3/8-5.91	0.375	0.945	1.949	5.906	3.937	1.260	M8x1.0mm	
WK032HMC		CAT40AD/B-HMC1/2-4.72	0.500	1.024	1.949	4.724	2.756	1.457	M10x1.0mm	
WK034HMC		CAT40AD/B-HMC1/2-5.91	0.500	1.024	1.949	5.906	3.937	1.457	M10x1.0mm	
WK036HMC		CAT40AD/B-HMC5/8-4.72	0.625	1.260	1.949	4.724	2.756	1.654	M12x1.0mm	
WK038HMC		CAT40AD/B-HMC5/8-5.91	0.625	1.260	1.949	5.906	3.937	1.654	M12x1.0mm	
WK040HMC		CAT40AD/B-HMC3/4-4.72	0.750	1.339	1.949	4.724	2.756	1.654	M16x1.0mm	
WK042HMC		CAT40AD/B-HMC3/4-5.91	0.750	1.339	1.949	5.906	3.937	1.654	M16x1.0mm	
WL020HMC		50	CAT50AD/B-HMC1/4-5.91	0.250	0.787	1.752	5.906	3.937	1.063	M5x0.8mm
WL022HMC			CAT50AD/B-HMC5/16-5.91	0.313	0.866	1.752	5.906	3.937	1.063	M6x1.0mm
WL024HMC	CAT50AD/B-HMC3/8-5.91		0.375	0.945	1.752	5.906	3.937	1.260	M8x1.0mm	
WL026HMC	CAT50AD/B-HMC1/2-5.91		0.500	1.024	1.752	5.906	3.937	1.457	M10x1.0mm	
WL028HMC	CAT50AD/B-HMC5/8-5.91		0.625	1.260	1.752	5.906	3.937	1.654	M12x1.0mm	
WL030HMC	CAT50AD/B-HMC3/4-5.91		0.750	1.339	1.752	5.906	3.937	1.654	M16x1.0mm	

Unit : mm

EDP No.	TAPER No.	MODEL No.	d1	D1	D2	L	L1	L2	G	
WK100HMC	40	CAT40AD/B-HMC6-120	6	20	49.5	120	70	27	M5X0.8	
WK102HMC		CAT40AD/B-HMC6-150	6	20	49.5	150	100	27	M5X0.8	
WK104HMC		CAT40AD/B-HMC8-120	8	22	49.5	120	70	27	M6X1.0	
WK106HMC		CAT40AD/B-HMC8-150	8	22	49.5	150	100	27	M6X1.0	
WK108HMC		CAT40AD/B-HMC10-120	10	24	49.5	120	70	32	M8X1.0	
WK110HMC		CAT40AD/B-HMC10-150	10	24	49.5	150	100	32	M8X1.0	
WK112HMC		CAT40AD/B-HMC12-120	12	25	49.5	120	70	37	M10X1.0	
WK114HMC		CAT40AD/B-HMC12-150	12	25	49.5	150	100	37	M10X1.0	
WK116HMC		CAT40AD/B-HMC16-120	16	32	49.5	120	70	42	M12X1.0	
WK118HMC		CAT40AD/B-HMC16-150	16	32	49.5	150	100	42	M12X1.0	
WK120HMC		CAT40AD/B-HMC20-120	20	34	49.5	120	70	42	M16X1.0	
WK122HMC		CAT40AD/B-HMC20-150	20	34	49.5	150	100	42	M16X1.0	
WL100HMC		50	CAT50AD/B-HMC6-150	6	20	44.5	150	100	27	M5X0.8
WL102HMC			CAT50AD/B-HMC8-150	8	22	44.5	150	100	27	M6X1.0
WL104HMC	CAT50AD/B-HMC10-150		10	24	44.5	150	100	32	M8X1.0	
WL106HMC	CAT50AD/B-HMC12-150		12	25	44.5	150	100	37	M10X1.0	
WL108HMC	CAT50AD/B-HMC16-150		16	32	44.5	150	100	42	M12X1.0	
WL110HMC	CAT50AD/B-HMC20-150		20	34	44.5	150	100	42	M16X1.0	

* Applicable Hydraulic Chuck collets(reduction sleeves) on page 29~36.

HYDRAULIC CHUCK (SLIM)

BT

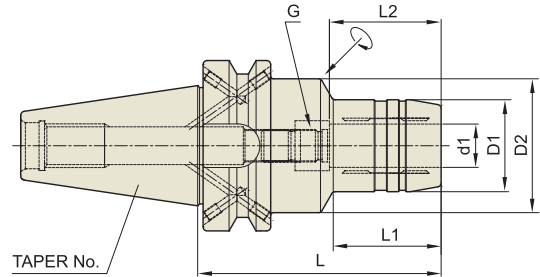

JIS B6339 - BT	Taper Accuracy AT3	G Value 2.5	RPM 25,000	Run-Out (at 3D) ≤0.00012"	Coolant System AD or AD/B
-----------------------	------------------------------	-----------------------	----------------------	-------------------------------------	-------------------------------------

JIS B6339/MAS 403-BT

Unit : inch

EDP No.	TAPER No.	MODEL No.	d1	D1	D2	L	L1	L2	G
WG020	30	BT30-HC1/4-2.75	0.250	1.024	1.752	2.750	1.161	1.063	M5x0.8mm
WG022		BT30-HC5/16-2.75	0.313	1.102	1.752	2.750	1.181	1.063	M6x1.0mm
WG024		BT30-HC3/8-2.95	0.375	1.181	1.752	2.953	1.220	1.260	M8x1.0mm
WG026		BT30-HC1/2-3.35	0.500	1.260	1.772	3.346	1.575	1.457	M10x1.0mm
WG028		BT30-HC5/8-3.54	0.625	1.496	1.772	3.543	1.811	1.654	M10x1.0mm
WG030		BT30-HC3/4-3.54	0.750	1.654	1.772	3.543	1.890	1.654	M6x1.0mm
WH020		40	BT40AD/B-HC1/4-3.54	0.250	1.024	1.752	3.543	1.181	1.063
WH022	BT40AD/B-HC5/16-3.54		0.313	1.102	1.752	3.543	1.280	1.063	M6x1.0mm
WH024	BT40AD/B-HC3/8-3.54		0.375	1.181	1.752	3.543	1.260	1.260	M8x1.0mm
WH026	BT40AD/B-HC1/2-3.54		0.500	1.260	1.752	3.543	1.378	1.457	M10x1.0mm
WH028	BT40AD/B-HC5/8-3.54		0.625	1.496	1.870	3.543	1.575	1.654	M12x1.0mm
WH030	BT40AD/B-HC3/4-3.54		0.750	1.654	1.870	3.543	1.575	1.654	M16x1.0mm
WH032	BT40AD/B-HC1"-3.94		1.000	1.969	2.362	3.937	1.772	1.890	M16x1.0mm
WH034	BT40AD/B-HC1 1/4-4.13		1.250	2.362	-	4.134	-	2.165	M16x1.0mm

* Applicable Hydraulic Chuck collets(reduction sleeves) on page 29~36.

HYDRAULIC CHUCK (SLIM)

BT

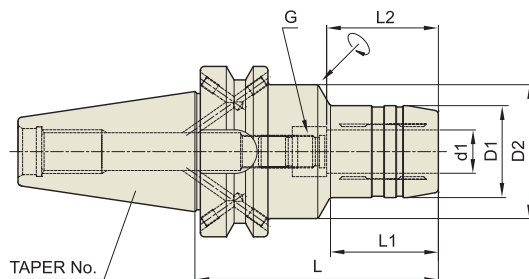

JIS B6339 -BT	Taper Accuracy AT3	G Value 2.5	RPM 25,000	Run-Out (at 3D) ≤0.00012"	Coolant System AD or AD/B
------------------	------------------------------	-----------------------	----------------------	-------------------------------------	-------------------------------------

JIS B6339/MAS 403-BT

Unit : mm

EDP No.	TAPER No.	MODEL No.	d1	D1	D2	L	L1	L2	G
WG100	30	BT30-HC6-70	6	26	44.5	70	29.5	27	M5x0.8
WG102		BT30-HC8-70	8	28	44.5	70	30	27	M6x1.0
WG104		BT30-HC10-75	10	30	44.5	75	31	32	M8x1.0
WG106		BT30-HC12-85	12	32	45	85	45	37	M10x1.0
WG108		BT30-HC14-85	14	34	45	85	45	37	M10x1.0
WG110		BT30-HC16-90	16	38	45	90	50	42	M10x1.0
WG112		BT30-HC18-90	18	40	45	90	50	42	M10x1.0
WG114		BT30-HC20-90	20	42	45	90	50	42	M6x1.0
WH100		BT40AD/B-HC6-90	6	26	44.5	90	43	27	M5x0.8
WH102	BT40AD/B-HC8-90	8	28	44.5	90	44.5	27	M6x1.0	
WH104	BT40AD/B-HC10-90	10	30	44.5	90	44.5	32	M8x1.0	
WH106	BT40AD/B-HC12-90	12	32	44.5	90	44.5	37	M10x1.0	
WH108	BT40AD/B-HC14-90	14	34	44.5	90	44.5	37	M10x1.0	
WH110	BT40AD/B-HC16-90	16	38	44.5	90	47.5	42	M12x1.0	
WH112	BT40AD/B-HC18-90	18	40	44.5	90	47.5	42	M12x1.0	
WH114	BT40AD/B-HC20-90	20	42	44.5	90	47.5	42	M16x1.0	
WH116	BT40AD/B-HC25-100	25	50	60	100	47.5	48	M16x1.0	
WH118	BT40AD/B-HC32-105	32	60	-	105	-	55	M16x1.0	

* Applicable Hydraulic Chuck collets(reduction sleeves) on page 29~36.

HYDRAULIC CHUCK (Power E Hydro) **NEW**

BT

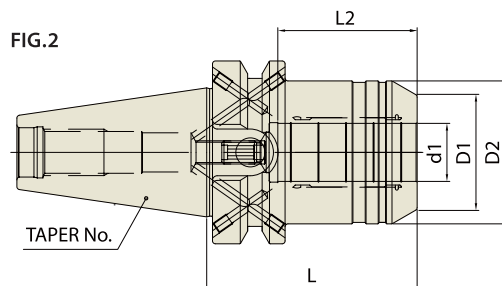
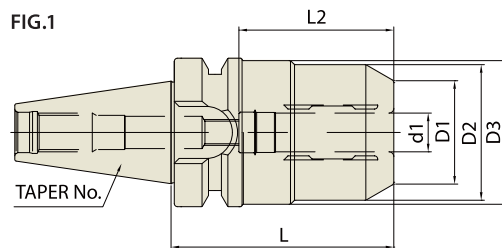

JIS B6339 - BT	Taper Accuracy AT3	G Value 2.5	RPM 25,000	Run-Out (at 3D) ≤0.00012"	Coolant System AD or AD/B
-----------------------	------------------------------	-----------------------	----------------------	-------------------------------------	-------------------------------------

JIS B6339/MAS 403-BT

Unit: inch

EDP No.	TAPER No.	MODEL No.	d1	D1	D2	D3	L	L2	G	FIG.
WG002PE	30	BT30-HC3/4P-3.543	0.75	1.496	1.653	1.751	3.543	1.889	M8x1.0mm	1
WH002PE	40	BT40AD/B-HC3/4P-2.854	0.75	1.496	1.938	-	2.854	1.889	M8x1.0mm	2
WI003PE	50	BT50AD/B-HC1 1/4P-3.543	1.25	2.303	2.834	-	3.543	2.244	M8x1.0mm	2

Unit: mm

EDP No.	TAPER No.	MODEL No.	d1	D1	D2	D3	L	L2	G	FIG.
WG100PE	30	BT30-HC12P-69	12	32	42	44.5	69	41	M8x1.0	1
WG102PE		BT30-HC20P-90	20	38	42	44.5	90	48	M8x1.0	1
WH100PE	40	BT40AD/B-HC12P-58	12	32	42	-	58	41	M8x1.0	2
WH102PE		BT40AD/B-HC20P-72.5	20	38	49.25	-	72.5	48	M8x1.0	2
WI100PE	50	BT50AD/B-HC20P-83.5	20	38	49.25	-	83.5	48	M8x1.0	2
WI102PE		BT50AD/B-HC32P-90	32	58.5	72	-	90	57	M8x1.0	2

- * High Clamping Torque Power version
(Please refer to page 137, Technical Information)
- * Applicable for milling(roughing and finishing)
- * Applicable Hydraulic Chuck collets(reduction sleeves) on page 29~36.

HYDRAULIC CHUCK (SHORT & RIGID)

BT

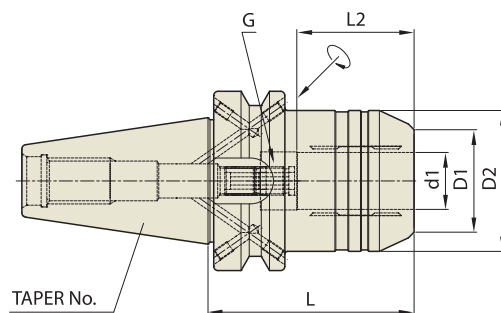

JIS B6339 -BT	Taper Accuracy AT3	G Value 2.5	RPM 25,000	Run-Out (at 3D) ≤0.00012"	Coolant System AD or AD/B
------------------	-----------------------	----------------	---------------	---------------------------------	------------------------------

JIS B6339/MAS 403-BT

Unit : mm

EDP No.	TAPER No.	MODEL No.	d1	D1	D2	L	L2	G
WG100SNR	30	BT30-HC20S-85	20	41	44	85	42	M6x1.0
WH100SNR	40	BT40AD/B-HC12S-58	12	32	42	58	37	M8x1.0
WH102SNR		BT40AD/B-HC20S-72.5	20	38	49.25	72.5	42	M8x1.0

* Applicable Hydraulic Chuck collets(reduction sleeves) on page 29~36.

HYDRAULIC CHUCK (RADIAL TOOL LENGTH PRE-SETTING TYPE)

BT

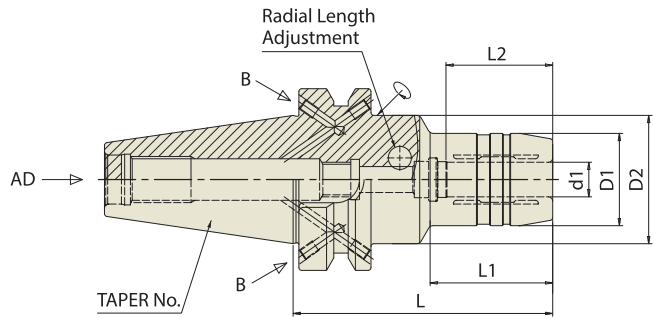

JIS B6339 -BT	Taper Accuracy AT3	G Value 2.5	RPM 25,000	Run-Out (at 3D) ≤0.00012"	Coolant System AD or AD/B
--------------------------	------------------------------	-----------------------	----------------------	-------------------------------------	-------------------------------------

JIS B6339/MAS 403-BT

Unit : mm

EDP No.	TAPER No.	MODEL No.	d1	D1	D2	L	L1	L2
WG100HCR	30	BT30-HCR12-85	12	32	44.5	85	40	37
WG102HCR		BT30-HCR20-85	20	44	-	85	-	42
WH100HCR	40	BT40AD/B-HCR12-90	12	32	44.5	90	42.5	37
WH102HCR		BT40AD/B-HCR20-90	20	42	44.5	90	47.5	42
WH104HCR		BT40AD/B-HCR32-105	32	60	-	105	-	55

* Applicable Hydraulic Chuck collets(reduction sleeves) on page 29~36.

HYDRAULIC CHUCK (For MOULD)

BT

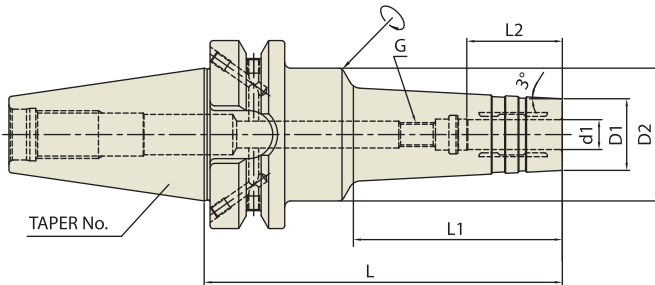

JIS B6339 -BT	Taper Accuracy AT3	G Value 2.5	RPM 25,000	Run-Out (at 3D) ≤0.00012"	Coolant System AD/B
----------------------	------------------------------	-----------------------	----------------------	-------------------------------------	-------------------------------

JIS B6339/MAS 403-BT

Unit : mm

EDP No.	TAPER No.	MODEL No.	d1	D1	D2	L	L1	L2	G
WH100HMC	40	BT40AD/B-HMC6-120	6	20	44.5	120	70	27	M5×0.8
WH102HMC		BT40AD/B-HMC6-150	6	20	44.5	150	100	27	M5×0.8
WH104HMC		BT40AD/B-HMC8-120	8	22	44.5	120	70	27	M6×1.0
WH106HMC		BT40AD/B-HMC8-150	8	22	44.5	150	100	27	M6×1.0
WH108HMC		BT40AD/B-HMC10-120	10	24	44.5	120	70	32	M8×1.0
WH110HMC		BT40AD/B-HMC10-150	10	24	44.5	150	100	32	M8×1.0
WH112HMC		BT40AD/B-HMC12-120	12	25	44.5	120	70	37	M10×1.0
WH114HMC		BT40AD/B-HMC12-150	12	25	44.5	150	100	37	M10×1.0
WH116HMC		BT40AD/B-HMC16-120	16	32	44.5	120	70	42	M12×1.0
WH118HMC		BT40AD/B-HMC16-150	16	32	44.5	150	100	42	M12×1.0
WH120HMC		BT40AD/B-HMC20-120	20	36	43.75	120	-	42	M16×1.0
WH122HMC		BT40AD/B-HMC20-150	20	36	46.9	150	-	42	M16×1.0

* Applicable Hydraulic Chuck collets(reduction sleeves) on page 29~36.

DUAL CONTACT HYDRAULIC CHUCK (SLIM)

CCT

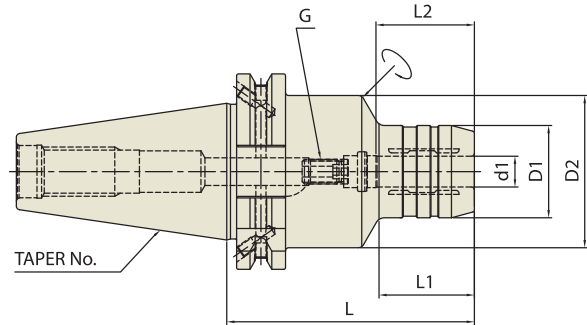

CCT	Taper Accuracy AT3	G Value 2.5	RPM 25,000	Run-Out (at 3D) ≤0.00012"	Coolant System AD/B
-----	------------------------------	-----------------------	----------------------	-------------------------------------	-------------------------------

CCT (CAT DUAL CONTACT)

Unit : inch

EDP No.	TAPER No.	MODEL No.	d1	D1	D2	L	L1	L2	G
WB020	40	CCT40AD/B-HC1/4-3.54	0.250	1.024	1.752	3.543	1.280	1.063	M5x0.8mm
WB022		CCT40AD/B-HC5/16-3.54	0.313	1.102	1.752	3.543	1.280	1.063	M6x1.0mm
WB024		CCT40AD/B-HC3/8-3.54	0.375	1.181	1.752	3.543	1.634	1.260	M8x1.0mm
WB026		CCT40AD/B-HC1/2-3.54	0.500	1.260	1.752	3.543	1.634	1.457	M10x1.0mm
WB028		CCT40AD/B-HC5/8-3.54	0.625	1.496	1.752	3.543	1.949	1.654	M10x1.0mm
WB030		CCT40AD/B-HC3/4-3.54	0.750	1.654	1.752	3.543	1.949	1.654	M10x1.0mm
WB032		CCT40AD/B-HC1"-3.94	1.000	2.165	2.480	3.937	2.559	1.890	M16x1.0mm
WB034		CCT40AD/B-HC1 1/4-4.13	1.250	2.480	3.150	4.134	1.378	2.165	M16x1.0mm
WC020		50	CCT50AD/B-HC1/4-3.54	0.250	1.024	1.969	3.543	1.181	1.063
WC022	CCT50AD/B-HC5/16-3.54		0.313	1.102	1.969	3.543	1.181	1.063	M6x1.0mm
WC024	CCT50AD/B-HC3/8-3.54		0.375	1.181	1.969	3.543	1.260	1.260	M8x1.0mm
WC026	CCT50AD/B-HC1/2-3.54		0.500	1.260	1.969	3.543	1.378	1.457	M10x1.0mm
WC028	CCT50AD/B-HC5/8-3.54		0.625	1.496	1.969	3.543	1.575	1.654	M10x1.0mm
WC030	CCT50AD/B-HC3/4-3.54		0.750	1.654	1.969	3.543	1.575	1.654	M10x1.0mm
WC032	CCT50AD/B-HC1"-4.13		1.000	2.244	2.480	4.134	2.047	1.890	M16x1.0mm
WC034	CCT50AD/B-HC1 1/4-4.53		1.250	2.480	2.953	4.528	2.441	2.165	M16x1.0mm

* Applicable Hydraulic Chuck collets(reduction sleeves) on page 29~36.

HYDRAULIC CHUCK (Power E Hydro) **NEW**

CCT

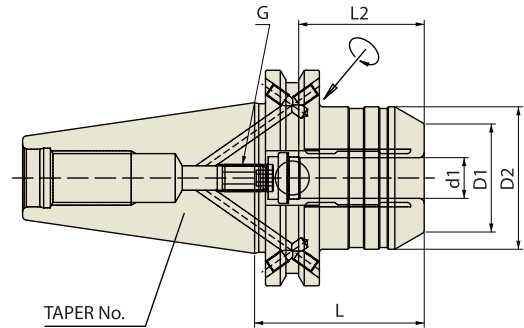

CCT	Taper Accuracy AT3	G Value 2.5	RPM 25,000	Run-Out (at 3D) ≤0.00012"	Coolant System AD/B
-----	------------------------------	-----------------------	----------------------	-------------------------------------	-------------------------------

CCT (CAT DUAL CONTACT)

Unit : inch

EDP No.	TAPER No.	MODEL No.	d1	D1	D2	L	L2	G
WB030PE	40	CCT40AD/B-HC3/4P-2.539	0.75	1.496	49.25	2.539	1.889	M8x1.0mm
WB031PE		CCT40AD/B-HC3/4P-4.000	0.75	1.496	49.25	4.000	1.889	M8x1.0mm

Unit : mm

EDP No.	TAPER No.	MODEL No.	d1	D1	D2	L	L2	G
WB130PE	40	CCT40AD/B-HC20P-64.5	20	38	49.25	64.5	48	M8x1.0
WB131PE		CCT40AD/B-HC20P-101.6	20	38	49.25	101.6	48	M8x1.0

- * High Clamping Torque Power version
(Please refer to page 137, Technical Information)
- * Applicable for milling(roughing and finishing)
- * Applicable Hydraulic Chuck collets(reduction sleeves) on page 29~36.

DUAL CONTACT HYDRAULIC CHUCK (For MOULD)

CCT

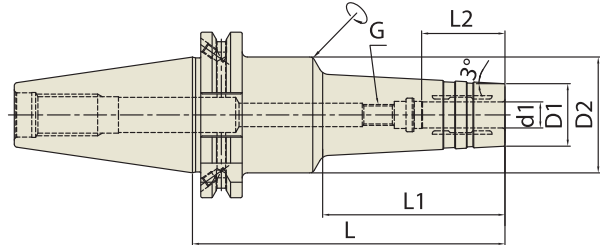

CCT	Taper Accuracy AT3	G Value 2.5	RPM 25,000	Run-Out (at 3D) ≤0.00012"	Coolant System AD/B
-----	------------------------------	-----------------------	----------------------	-------------------------------------	-------------------------------

CCT (CAT DUAL CONTACT)

Unit : inch

EDP No.	TAPER No.	MODEL No.	d1	D1	D2	L	L1	L2	G	
WB020HMC	40	CCT40AD/B-HMC1/4-4.72	0.250	0.787	1.949	4.724	2.756	1.063	M5x0.8mm	
WB022HMC		CCT40AD/B-HMC1/4-5.91	0.250	0.787	1.949	5.906	3.937	1.063	M5x0.8mm	
WB024HMC		CCT40AD/B-HMC5/16-4.72	0.313	0.866	1.949	4.724	2.756	1.063	M6x1.0mm	
WB026HMC		CCT40AD/B-HMC5/16-5.91	0.313	0.866	1.949	5.906	3.937	1.063	M6x1.0mm	
WB028HMC		CCT40AD/B-HMC3/8-4.72	0.375	0.945	1.949	4.724	2.756	1.260	M8x1.0mm	
WB030HMC		CCT40AD/B-HMC3/8-5.91	0.375	0.945	1.949	5.906	3.937	1.260	M8x1.0mm	
WB032HMC		CCT40AD/B-HMC1/2-4.72	0.500	1.024	1.949	4.724	2.756	1.457	M10x1.0mm	
WB034HMC		CCT40AD/B-HMC1/2-5.91	0.500	1.024	1.949	5.906	3.937	1.457	M10x1.0mm	
WB036HMC		CCT40AD/B-HMC5/8-4.72	0.625	1.260	1.949	4.724	2.756	1.654	M12x1.0mm	
WB038HMC		CCT40AD/B-HMC5/8-5.91	0.625	1.260	1.949	5.906	3.937	1.654	M12x1.0mm	
WB040HMC		CCT40AD/B-HMC3/4-4.72	0.750	1.339	1.949	4.724	2.756	1.654	M16x1.0mm	
WB042HMC		CCT40AD/B-HMC3/4-5.91	0.750	1.339	1.949	5.906	3.937	1.654	M16x1.0mm	
WC020HMC		50	CCT50AD/B-HMC1/4-5.91	0.250	0.787	1.752	5.906	3.937	1.063	M5x0.8mm
WC022HMC			CCT50AD/B-HMC5/16-5.91	0.313	0.866	1.752	5.906	3.937	1.063	M6x1.0mm
WC024HMC	CCT50AD/B-HMC3/8-5.91		0.375	0.945	1.752	5.906	3.937	1.260	M8x1.0mm	
WC026HMC	CCT50AD/B-HMC1/2-5.91		0.500	1.024	1.752	5.906	3.937	1.457	M10x1.0mm	
WC028HMC	CCT50AD/B-HMC5/8-5.91		0.625	1.260	1.752	5.906	3.937	1.654	M12x1.0mm	
WC030HMC	CCT50AD/B-HMC3/4-5.91		0.750	1.339	1.752	5.906	3.937	1.654	M16x1.0mm	

Unit : mm

EDP No.	TAPER No.	MODEL No.	d1	D1	D2	L	L1	L2	G	
WB100HMC	40	CCT40AD/B-HMC6-120	6	20	49.5	120	70	27	M5X0.8	
WB102HMC		CCT40AD/B-HMC6-150	6	20	49.5	150	100	27	M5X0.8	
WB104HMC		CCT40AD/B-HMC8-120	8	22	49.5	120	70	27	M6X1.0	
WB106HMC		CCT40AD/B-HMC8-150	8	22	49.5	150	100	27	M6X1.0	
WB108HMC		CCT40AD/B-HMC10-120	10	24	49.5	120	70	32	M8X1.0	
WB110HMC		CCT40AD/B-HMC10-150	10	24	49.5	150	100	32	M8X1.0	
WB112HMC		CCT40AD/B-HMC12-120	12	25	49.5	120	70	37	M10X1.0	
WB114HMC		CCT40AD/B-HMC12-150	12	25	49.5	150	100	37	M10X1.0	
WB116HMC		CCT40AD/B-HMC16-120	16	32	49.5	120	70	42	M12X1.0	
WB118HMC		CCT40AD/B-HMC16-150	16	32	49.5	150	100	42	M12X1.0	
WB120HMC		CCT40AD/B-HMC20-120	20	34	49.5	120	70	42	M16X1.0	
WB122HMC		CCT40AD/B-HMC20-150	20	34	49.5	150	100	42	M16X1.0	
WC100HMC		50	CCT50AD/B-HMC6-150	6	20	44.5	150	100	27	M5X0.8
WC102HMC			CCT50AD/B-HMC8-150	8	22	44.5	150	100	27	M6X1.0
WC104HMC	CCT50AD/B-HMC10-150		10	24	44.5	150	100	32	M8X1.0	
WC106HMC	CCT50AD/B-HMC12-150		12	25	44.5	150	100	37	M10X1.0	
WC108HMC	CCT50AD/B-HMC16-150		16	32	44.5	150	100	42	M12X1.0	
WC110HMC	CCT50AD/B-HMC20-150		20	34	44.5	150	100	42	M16X1.0	

* Applicable Hydraulic Chuck collets(reduction sleeves) on page 29~36.

DUAL CONTACT HYDRAULIC CHUCK (SLIM)

CBT

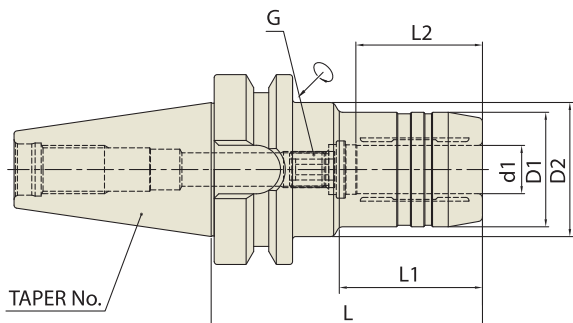

CBT	Taper Accuracy AT3	G Value 2.5	RPM 25,000	Run-Out (at 3D) ≤0.00012"	Coolant System AD
-----	------------------------------	-----------------------	----------------------	-------------------------------------	-----------------------------

CBT (BT DUAL CONTACT)

Unit : inch

EDP No.	TAPER No.	MODEL No.	d1	D1	D2	L	L1	L2	G
WD020	30	CBT30-HC1/4-2.76	0.250	1.024	1.752	2.756	1.161	1.063	M5x0.8mm
WD022		CBT30-HC5/16-2.76	0.313	1.102	1.752	2.756	1.181	1.063	M6x1.0mm
WD024		CBT30-HC3/8-2.95	0.375	1.181	1.752	2.953	1.220	1.260	M8x1.0mm
WD026		CBT30-HC1/2-3.35	0.500	1.260	1.772	3.346	1.575	1.457	M10x1.0mm
WD028		CBT30-HC5/8-3.54	0.625	1.496	1.772	3.543	1.811	1.654	M10x1.0mm
WD030		CBT30-HC3/4-3.54	0.750	1.654	1.772	3.543	1.890	1.654	M16x1.0mm
WE020	40	CBT40-HC1/4-3.54	0.250	1.024	1.752	3.543	1.181	1.063	M5x0.8mm
WE022		CBT40-HC5/16-3.54	0.313	1.102	1.752	3.543	1.280	1.063	M6x1.0mm
WE024		CBT40-HC3/8-3.54	0.375	1.181	1.752	3.543	1.260	1.260	M8x1.0mm
WE026		CBT40-HC1/2-3.54	0.500	1.260	1.752	3.543	1.378	1.457	M10x1.0mm
WE028		CBT40-HC5/8-3.54	0.625	1.496	1.870	3.543	1.575	1.654	M12x1.0mm
WE030		CBT40-HC3/4-3.54	0.750	1.654	1.870	3.543	1.575	1.654	M16x1.0mm
WE032		CBT40-HC1"-3.94	1.000	1.969	2.362	3.937	1.772	1.890	M16x1.0mm
WE034		CBT40-HC1 1/4-4.13	1.250	2.362	-	4.134	-	2.165	M16x1.0mm

Unit : mm

EDP No.	TAPER No.	MODEL No.	d1	D1	D2	L	L1	L2	G
WD100	30	CBT30-HC6-70	6	26	44.5	70	29.5	27	M5x0.8
WD102		CBT30-HC8-70	8	28	44.5	70	30	27	M6x1.0
WD104		CBT30-HC10-75	10	30	44.5	75	31	32	M8x1.0
WD106		CBT30-HC12-85	12	32	45	85	45	37	M10x1.0
WD108		CBT30-HC14-85	14	34	45	85	45	37	M10x1.0
WD110		CBT30-HC16-90	16	38	45	90	50	42	M10x1.0
WD112		CBT30-HC18-90	18	40	45	90	50	42	M10x1.0
WD114		CBT30-HC20-90	20	42	45	90	50	42	M6x1.0
WE100	40	CBT40-HC6-90	6	26	44.5	90	43	27	M5x0.8
WE102		CBT40-HC8-90	8	28	44.5	90	44.5	27	M6x1.0
WE104		CBT40-HC10-90	10	30	44.5	90	44.5	32	M8x1.0
WE106		CBT40-HC12-90	12	32	44.5	90	44.5	37	M10x1.0
WE108		CBT40-HC14-90	14	34	44.5	90	44.5	37	M10x1.0
WE110		CBT40-HC16-90	16	38	44.5	90	47.5	42	M12x1.0
WE112		CBT40-HC18-90	18	40	44.5	90	47.5	42	M12x1.0
WE114		CBT40-HC20-90	20	42	44.5	90	47.5	42	M16x1.0
WE116		CBT40-HC25-100	25	50	60	100	47.5	48	M16x1.0
WE118		CBT40-HC32-105	32	60	-	105	-	55	M16x1.0

* Applicable Hydraulic Chuck collets(reduction sleeves) on page 29~36.

HYDRAULIC CHUCK (Power E Hydro) **NEW**

CBT

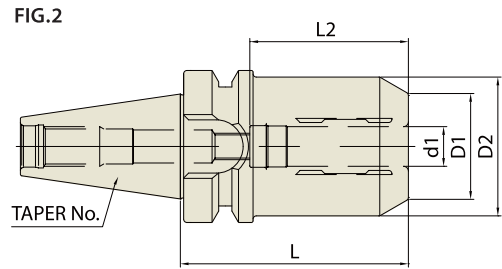
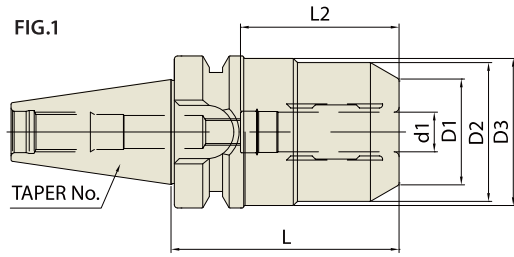

CBT	Taper Accuracy AT3	G Value 2.5	RPM 25,000	Run-Out (at 3D) ≤0.00012"	Coolant System AD
------------	------------------------------	-----------------------	----------------------	-------------------------------------	-----------------------------

CBT (BT DUAL CONTACT)

Unit : inch

EDP No.	TAPER No.	MODEL No.	d1	D1	D2	D3	L	L2	G	FIG.
WD030PE	30	CBT30-HC3/4P-3.543	0.75	1.496	1.653	1.751	3.543	1.889	M8x1.0mm	1
WE030PE	40	CBT40-HC3/4P-2.854	0.75	1.496	1.938	-	2.854	1.889	M8x1.0mm	2

Unit : mm

EDP No.	TAPER No.	MODEL No.	d1	D1	D2	D3	L	L2	G	FIG.
WD112PE	30	CBT30-HC12P-69	12	32	42	44.5	69	41	M8x1.0	1
WD120PE		CBT30-HC20P-90	20	38	42	44.5	90	48	M8x1.0	1
WE112PE	40	CBT40-HC12P-58	12	32	42	-	58	41	M8x1.0	2
WE120PE		CBT40-HC20P-72.5	20	38	49.25	-	72.5	48	M8x1.0	2

- * High Clamping Torque Power version
(Please refer to page 137, Technical Information)
- * Applicable for milling(roughing and finishing)
- * Applicable Hydraulic Chuck collets(reduction sleeves) on page 29~36.

DUAL CONTACT HYDRAULIC CHUCK (For MOULD)

CBT

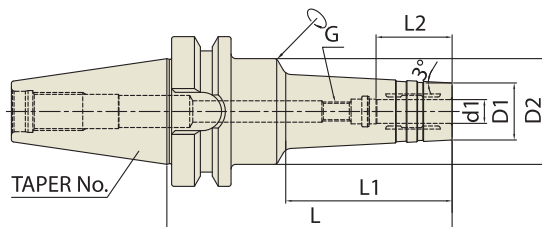

CBT	Taper Accuracy AT3	G Value 2.5	RPM 25,000	Run-Out (at 3D) ≤0.00012"	Coolant System AD
-----	------------------------------	-----------------------	----------------------	-------------------------------------	-----------------------------

CBT (BT DUAL CONTACT)

Unit : inch

EDP No.	TAPER No.	MODEL No.	d1	D1	D2	L	L1	L2	G
WE020HMC	40	CBT40-HMC1/4-4.72	0.250	0.787	1.752	4.724	2.756	1.063	M5x0.8mm
WE022HMC		CBT40-HMC1/4-5.91	0.250	0.787	1.752	5.906	3.937	1.063	M5x0.8mm
WE024HMC		CBT40-HMC5/16-4.72	0.313	0.866	1.752	4.724	2.756	1.063	M6x1.0mm
WE026HMC		CBT40-HMC5/16-5.91	0.313	0.866	1.752	5.906	3.937	1.063	M6x1.0mm
WE028HMC		CBT40-HMC3/8-4.72	0.375	0.945	1.752	4.724	2.756	1.260	M8x1.0mm
WE030HMC		CBT40-HMC3/8-5.91	0.375	0.945	1.752	5.906	3.937	1.260	M8x1.0mm
WE032HMC		CBT40-HMC1/2-4.72	0.500	1.024	1.752	4.724	2.756	1.457	M10x1.0mm
WE034HMC		CBT40-HMC1/2-5.91	0.500	1.024	1.752	5.906	3.937	1.457	M10x1.0mm
WE036HMC		CBT40-HMC5/8-4.72	0.625	1.260	1.752	4.724	2.756	1.654	M12x1.0mm
WE038HMC		CBT40-HMC5/8-5.91	0.625	1.260	1.752	5.906	3.937	1.654	M12x1.0mm
WE040HMC		CBT40-HMC3/4-4.72	0.750	1.339	1.722	4.724	-	1.654	M16x1.0mm
WE042HMC		CBT40-HMC3/4-5.91	0.750	1.339	1.846	5.906	-	1.654	M16x1.0mm

Unit : mm

EDP No.	TAPER No.	MODEL No.	d1	D1	D2	L	L1	L2	G
WE100HMC	40	CBT40-HMC6-120	6	20	44.5	120	70	27	M5x0.8
WE102HMC		CBT40-HMC6-150	6	20	44.5	150	100	27	M5x0.8
WE104HMC		CBT40-HMC8-120	8	22	44.5	120	70	27	M6x1.0
WE106HMC		CBT40-HMC8-150	8	22	44.5	150	100	27	M6x1.0
WE108HMC		CBT40-HMC10-120	10	24	44.5	120	70	32	M8x1.0
WE110HMC		CBT40-HMC10-150	10	24	44.5	150	100	32	M8x1.0
WE112HMC		CBT40-HMC12-120	12	25	44.5	120	70	37	M10x1.0
WE114HMC		CBT40-HMC12-150	12	25	44.5	150	100	37	M10x1.0
WE116HMC		CBT40-HMC16-120	16	32	44.5	120	70	42	M12x1.0
WE118HMC		CBT40-HMC16-150	16	32	44.5	150	100	42	M12x1.0
WE120HMC		CBT40-HMC20-120	20	34	43.8	120	-	42	M16x1.0
WE122HMC		CBT40-HMC20-150	20	34	46.9	150	-	42	M16x1.0

* Applicable Hydraulic Chuck collets(reduction sleeves) on page 29~36.

DUAL CONTACT HYDRAULIC CHUCK (SLIM)

HSK

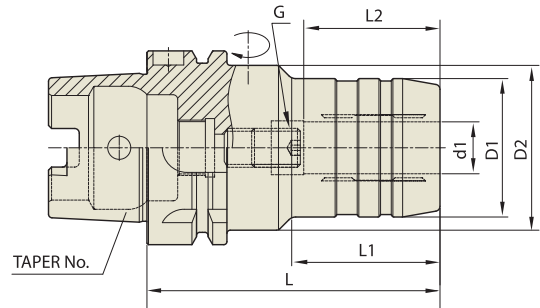

DIN 69893 - HSK	Taper Accuracy -	G Value 2.5	RPM 25,000	Run-Out (at 3D) ≤0.00012"	Coolant System AD
---------------------------	---------------------	----------------	---------------	------------------------------	----------------------

DIN 69893/ISO 12164-1 HSK FROM A

Unit : inch

EDP No.	TAPER No.	MODEL No.	d1	D1	D2	L	L1	L2	G
WQ020	63A	HSK63A-HC1/4-2.76	0.250	1.024	1.969	2.756	0.945	1.063	M5x0.8mm
WQ022		HSK63A-HC3/8-3.15	0.375	1.181	1.969	3.150	1.378	1.260	M8x1.0mm
WQ024		HSK63A-HC1/2-3.35	0.500	1.260	1.969	3.346	1.575	1.457	M10x1.0mm
WQ026		HSK63A-HC3/4-3.54	0.750	1.654	1.969	3.543	1.890	1.654	M16x1.0mm
WQ028		HSK63A-HC1"-4.72	1.000	2.244	2.480	4.724	2.323	1.890	M16x1.0mm
WQ030		HSK63A-HC1 1/4-4.92	1.250	2.520	2.953	4.921	2.480	2.165	M16x1.0mm
WR020	100A	HSK100A-HC1/4-2.95	0.250	1.024	1.969	2.953	1.024	1.063	M5x0.8mm
WR022		HSK100A-HC3/8-2.95	0.375	1.181	1.969	3.543	1.654	1.260	M8x1.0mm
WR024		HSK100A-HC1/2-3.74	0.500	1.260	1.969	3.740	1.850	1.457	M10x1.0mm
WR026		HSK100A-HC3/4-4.13	0.750	1.654	1.969	4.134	2.323	1.654	M16x1.0mm
WR028		HSK100A-HC1"-4.33	1.000	2.244	2.480	4.331	2.441	1.890	M16x1.0mm
WR032		HSK100A-HC1 1/4-4.33	1.250	2.520	2.953	4.331	2.441	2.165	M16x1.0mm

* Applicable Hydraulic Chuck collets(reduction sleeves) on page 29~36.

HYDRAULIC CHUCK (Power E Hydro) **NEW**

HSK

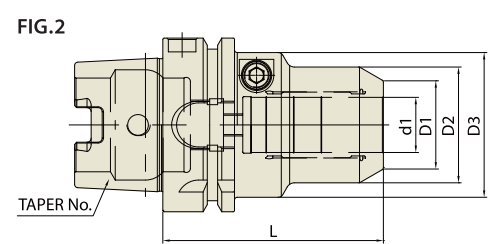
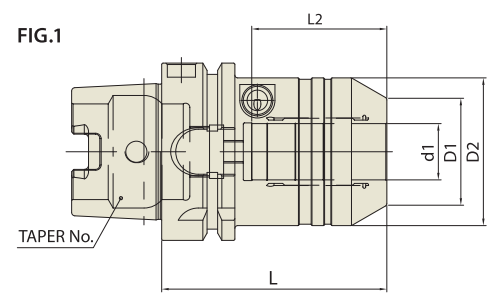

DIN 69893 - HSK	Taper Accuracy -	G Value 2.5	RPM 25,000	Run-Out (at 3D) ≤0.00012"	Coolant System AD
---------------------------	----------------------------	-----------------------	----------------------	-------------------------------------	-----------------------------

DIN 69893/ISO 12164-1-HSK FORM A

Unit : inch

EDP No.	TAPER No.	MODEL No.	d1	D1	D2	D3	L	L2	G	FIG.
WQ002PE	63A	HSK63A-HC3/4P-3.149	0.75	1.496	2.066	-	3.149	1.889	M8x1.0mm	1
WQ003PE		HSK63A-HC3/4P-5.118	0.75	1.496	2.066	-	5.118	1.889	M8x1.0mm	1
WR002PE	100A	HSK100A-HC1 1/4P-3.937	1.25	2.303	2.834	-	3.937	2.244	M8x1.0mm	1

Unit : mm

EDP No.	TAPER No.	MODEL No.	d1	D1	D2	D3	L	L2	G	FIG.
WQ100PE	63A	HSK63A-HC12P-80	12	32	42	52.5	80	41	M8x1.0	2
WQ102PE		HSK63A-HC20P-80	20	38	52.5	-	80	48	M8x1.0	1
WR100PE	100A	HSK100A-HC20P-90	20	38	52.5	-	90	48	M8x1.0	1
WR102PE		HSK100A-HC32P-100	32	58.5	72	-	100	57	M8x1.0	1

- * High Clamping Torque Power version
(Please refer to page 137, Technical Information)
- * Applicable for milling(roughing and finishing)
- * Applicable Hydraulic Chuck collets(reduction sleeves) on page 29~36.

DUAL CONTACT HYDRAULIC CHUCK (SHORT & RIGID)

HSK

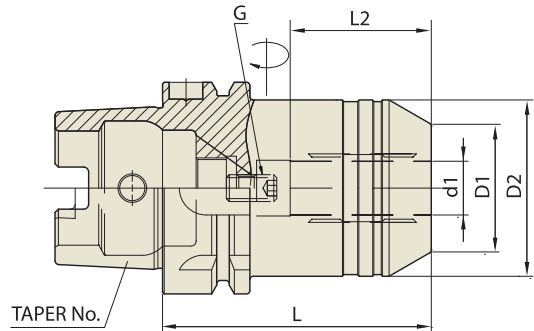

DIN 69893 - HSK	Taper Accuracy -	G Value 2.5	RPM 25,000	Run-Out (at 3D) ≤0.00012"	Coolant System AD
---------------------------	----------------------------	-----------------------	----------------------	-------------------------------------	-----------------------------

DIN 69893/ISO 12164-1-HSK FORM A

Unit : mm

EDP No.	TAPER No.	MODEL No.	d1	D1	D2	L	L2	G
WQ100SNR	63A	HSK63A-HC12S-80	12	32	42	80	37	M8x1.0
WQ102SNR		HSK63A-HC20S-80	20	38	52.5	80	42	M8x1.0
WR100SNR	100A	HSK100A-HC12S-85	12	32	42	85	35	M8x1.0
WR102SNR		HSK100A-HC20S-90	20	38	52.5	90	42	M8x1.0

* Applicable Hydraulic Chuck collets(reduction sleeves) on page 29~36.

DUAL CONTACT HYDRAULIC CHUCK (RADIAL TOOL LENGTH PRE-SETTING TYPE)

HSK

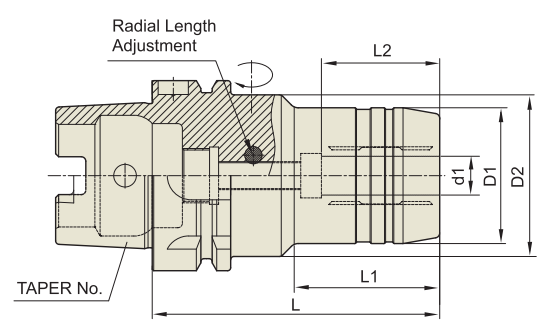

DIN 69893 - HSK	Taper Accuracy -	G Value 2.5	RPM 25,000	Run-Out (at 3D) ≤0.00012"	Coolant System AD
---------------------------	----------------------------	-----------------------	----------------------	-------------------------------------	-----------------------------

DIN 69893/ISO 12164-1-HSK FORM A

Unit : mm

EDP No.	TAPER No.	MODEL No.	d1	D1	D2	L	L1	L2
WQ100HCR	63A	HSK63A-HCR6-85	6	26	50	85	33	27
WQ102HCR		HSK63A-HCR8-85	8	28	50	85	33	27
WQ104HCR		HSK63A-HCR10-85	10	30	50	85	38	32
WQ106HCR		HSK63A-HCR12-95	12	32	50	95	40	37
WQ108HCR		HSK63A-HCR14-95	14	34	50	95	46	37
WQ110HCR		HSK63A-HCR16-95	16	38	50	95	51	42
WQ112HCR		HSK63A-HCR18-95	18	40	50	95	52	42
WQ114HCR		HSK63A-HCR20-100	20	42	50	100	51	42
WQ116HCR		HSK63A-HCR25-120	25	57	63	120	54.5	48
WQ118HCR		HSK63A-HCR32-125	32	64	75	125	57.5	55
WR100HCR		100A	HSK100A-HCR6-90	6	26	63	90	33
WR102HCR	HSK100A-HCR8-90		8	28	63	90	33	27
WR104HCR	HSK100A-HCR10-95		10	30	63	95	36	32
WR106HCR	HSK100A-HCR12-100		12	32	63	100	40	37
WR108HCR	HSK100A-HCR14-100		14	34	63	100	41	37
WR110HCR	HSK100A-HCR16-105		16	38	63	105	46	42
WR112HCR	HSK100A-HCR18-105		18	40	63	105	46	42
WR114HCR	HSK100A-HCR20-105		20	42	75	105	51	42
WR116HCR	HSK100A-HCR25-115		25	57	75	115	55.5	48
WR118HCR	HSK100A-HCR32-120		32	64	75	120	63.5	55

* Applicable Hydraulic Chuck collets(reduction sleeves) on page 29~36.

DUAL CONTACT HYDRAULIC CHUCK (For MOULD)

HSK

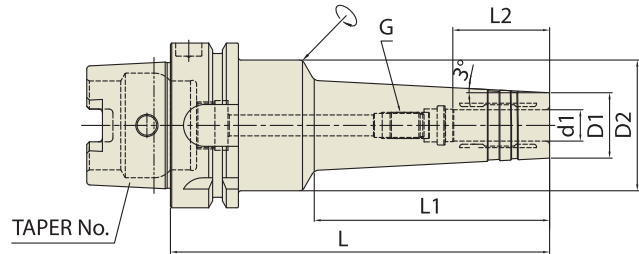

DIN 69893 -HSK	Taper Accuracy -	G Value 2.5	RPM 25,000	Run-Out (at 3D) ≤0.00012"	Coolant System AD
--------------------------	---------------------	----------------	---------------	------------------------------	----------------------

DIN 69893/ISO 12164-1-HSK FORM A

Unit : inch

EDP No.	TAPER No.	MODEL No.	d1	D1	D2	L	L1	L2	G
WQ020HMC	63A	HSK63A-HMC1/4-5.71	0.250	0.787	1.969	5.709	3.543	1.063	M5x0.8mm
WQ022HMC		HSK63A-HMC5/16-5.71	0.313	0.866	1.969	5.709	3.543	1.063	M6x1.0mm
WQ024HMC		HSK63A-HMC3/8-5.71	0.375	0.945	1.969	5.709	3.543	1.260	M8x1.0mm
WQ026HMC		HSK63A-HMC1/2-5.71	0.500	1.024	1.969	5.709	3.543	1.457	M10x1.0mm
WQ028HMC		HSK63A-HMC5/8-5.71	0.625	1.260	1.969	5.709	3.543	1.654	M12x1.0mm
WQ030HMC		HSK63A-HMC3/4-5.71	0.750	1.339	1.969	5.709	3.543	1.654	M16x1.0mm
WR100HMC	100A	HSK100A-HMC1/4-5.71	0.250	0.787	1.969	5.709	3.543	1.063	M5x0.8mm
WR102HMC		HSK100A-HMC5/16-5.71	0.313	0.866	1.969	5.709	3.543	1.063	M6x1.0mm
WR104HMC		HSK100A-HMC3/8-5.71	0.375	0.945	1.969	5.709	3.543	1.260	M8x1.0mm
WR106HMC		HSK100A-HMC1/2-5.71	0.500	1.024	1.969	5.709	3.543	1.457	M10x1.0mm
WR108HMC		HSK100A-HMC5/8-5.71	0.625	1.260	1.969	5.709	3.543	1.654	M12x1.0mm
WR110HMC		HSK100A-HMC3/4-5.71	0.750	1.339	1.969	5.709	3.543	1.654	M16x1.0mm

Unit : mm

EDP No.	TAPER No.	MODEL No.	d1	D1	D2	L	L1	L2	G
WQ100HMC	63A	HSK63A-HMC6-145	6	20	50	145	90	27	M5x0.8
WQ102HMC		HSK63A-HMC8-145	8	22	50	145	90	27	M6x1.0
WQ104HMC		HSK63A-HMC10-145	10	24	50	145	90	32	M8x1.0
WQ106HMC		HSK63A-HMC12-145	12	25	50	145	90	37	M10x1.0
WQ108HMC		HSK63A-HMC16-145	16	32	50	145	90	42	M12x1.0
WQ110HMC		HSK63A-HMC20-145	20	34	50	145	90	42	M16x1.0
WR200HMC	100A	HSK100A-HMC6-150	6	20	50	150	90	27	M5x0.8
WR202HMC		HSK100A-HMC8-150	8	22	50	150	90	27	M6x1.0
WR204HMC		HSK100A-HMC10-150	10	24	50	150	90	32	M8x1.0
WR206HMC		HSK100A-HMC12-150	12	25	50	150	90	37	M10x1.0
WR208HMC		HSK100A-HMC16-150	16	32	50	150	90	42	M12x1.0
WR210HMC		HSK100A-HMC20-150	20	34	50	150	90	42	M16x1.0

* Applicable Hydraulic Chuck collets(reduction sleeves) on page 29~36.

HYDRAULIC CHUCK COLLET (REDUCTION SLEEVE : OPEN TYPE)

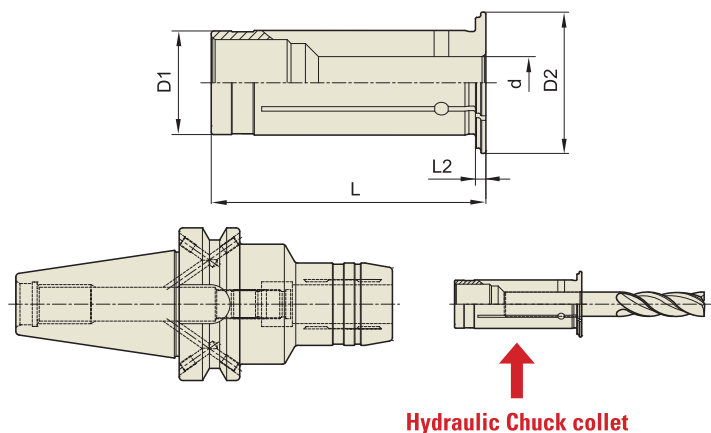

METRIC / INCH

Unit : inch

EDP No.	TYPE	d	D1	D2	L	L2	
412108	HK12	1/8"	0.125	0.472	0.748	1.850	0.079
412316		3/16"	0.188	0.472	0.748	1.850	0.079
412104		1/4"	0.250	0.472	0.748	1.850	0.079
412516		5/16"	0.313	0.472	0.748	1.850	0.079
420108	HK20	1/8"	0.125	0.787	1.063	2.067	0.079
420316		3/16"	0.188	0.787	1.063	2.067	0.079
420104		1/4"	0.250	0.787	1.063	2.067	0.079
420516		5/16"	0.313	0.787	1.063	2.067	0.079
420308		3/8"	0.375	0.787	1.063	2.067	0.079
420102		1/2"	0.500	0.787	1.063	2.067	0.079
420508	5/8"	0.625	0.787	1.063	2.067	0.079	
432108	HK32	1/8"	0.125	1.260	1.535	2.500	0.118
432316		3/16"	0.188	1.260	1.535	2.500	0.118
432104		1/4"	0.250	1.260	1.535	2.500	0.118
432516		5/16"	0.313	1.260	1.535	2.500	0.118
432308		3/8"	0.375	1.260	1.535	2.500	0.118
432102		1/2"	0.500	1.260	1.535	2.500	0.118
432508		5/8"	0.625	1.260	1.535	2.500	0.118
432304		3/4"	0.750	1.260	1.535	2.500	0.118
432100		1	1.000	1.260	1.535	2.500	0.118

* Other special sizes of Hydraulic Chuck collets can be supplied on request.

Feature

Hydraulic Chuck collet(reduction sleeve) is cut into trisection by high precision cutting to guarantee precise I.D and strong clamping power.

Chucking Method

Please assemble cutting tool with collet first, and then insert collet into Hydraulic Chuck.

HYDRAULIC CHUCK COLLET (REDUCTION SLEEVE : CLOSED TYPE)

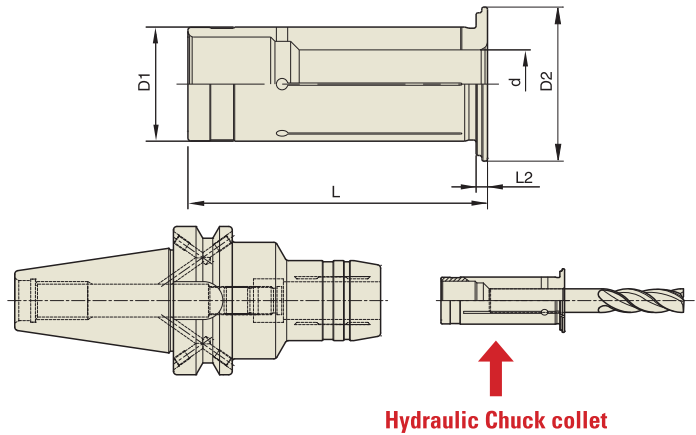

METRIC / INCH

Unit : inch

EDP No.	TYPE	d	D1	D2	L	L2	
512108	HS12	1/8"	0.125	0.472	0.748	1.850	0.079
512316		3/16"	0.188	0.472	0.748	1.850	0.079
512104		1/4"	0.250	0.472	0.748	1.850	0.079
512516		5/16"	0.313	0.472	0.748	1.850	0.079
520108	HS20	1/8"	0.125	0.787	1.063	2.067	0.079
520316		3/16"	0.188	0.787	1.063	2.067	0.079
520104		1/4"	0.250	0.787	1.063	2.067	0.079
520516		5/16"	0.313	0.787	1.063	2.067	0.079
520308		3/8"	0.375	0.787	1.063	2.067	0.079
520102		1/2"	0.500	0.787	1.063	2.067	0.079
520508	5/8"	0.625	0.787	1.063	2.067	0.079	
532108	HS32	1/8"	0.125	1.260	1.535	2.500	0.118
532316		3/16"	0.188	1.260	1.535	2.500	0.118
532104		1/4"	0.250	1.260	1.535	2.500	0.118
532516		5/16"	0.313	1.260	1.535	2.500	0.118
532308		3/8"	0.375	1.260	1.535	2.500	0.118
532102		1/2"	0.500	1.260	1.535	2.500	0.118
532508		5/8"	0.625	1.260	1.535	2.500	0.118
532304		3/4"	0.750	1.260	1.535	2.500	0.118
532100		1	1.000	1.260	1.535	2.500	0.118

* Other special sizes of Hydraulic Chuck collets can be supplied on request.

Feature

The wall of Hydraulic Chuck collet(reduction sleeve) is cut by high precision wire-cutting to guarantee precise I.D and strong clamping power.

Chucking Method

Please assemble cutting tool with collet first, and then insert collet into Hydraulic Chuck.

HYDRAULIC CHUCK COLLET (REDUCTION SLEEVE : OPEN TYPE)

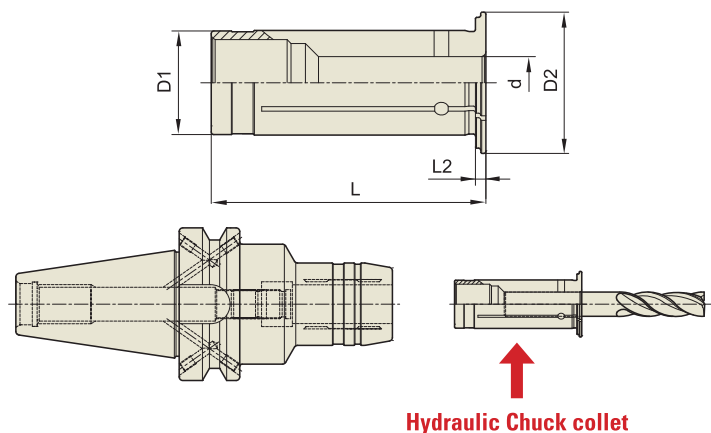

INCH / INCH

Unit : inch

EDP No.	TYPE	d	D1	D2	L	L2	
612108	HK1/2"	1/8"	0.125	0.500	0.748	1.850	0.079
612316		3/16"	0.188	0.500	0.748	1.850	0.079
612104		1/4"	0.250	0.500	0.748	1.850	0.079
612516		5/16"	0.313	0.500	0.748	1.850	0.079
625108	HK3/4"	1/8"	0.125	0.750	1.063	2.067	0.079
625316		3/16"	0.188	0.750	1.063	2.067	0.079
625104		1/4"	0.250	0.750	1.063	2.067	0.079
625516		5/16"	0.313	0.750	1.063	2.067	0.079
625308		3/8"	0.375	0.750	1.063	2.067	0.079
625102		1/2"	0.500	0.750	1.063	2.067	0.079
625508	5/8"	0.625	0.750	1.063	2.067	0.079	
632108	HK1 1/4"	1/8"	0.125	1.250	1.535	2.500	0.118
632316		3/16"	0.188	1.250	1.535	2.500	0.118
632104		1/4"	0.250	1.250	1.535	2.500	0.118
632516		5/16"	0.313	1.250	1.535	2.500	0.118
632308		3/8"	0.375	1.250	1.535	2.500	0.118
632102		1/2"	0.500	1.250	1.535	2.500	0.118
632508		5/8"	0.625	1.250	1.535	2.500	0.118
632304		3/4"	0.750	1.250	1.535	2.500	0.118
632100		1	1.000	1.250	1.535	2.500	0.118

* Other special sizes of Hydraulic Chuck collets can be supplied on request.

Feature

Hydraulic Chuck collet(reduction sleeve) is cut into trisection by high precision cutting to guarantee precise I.D and strong clamping power.

Chucking Method

Please assemble cutting tool with collet first, and then insert collet into Hydraulic Chuck.

HYDRAULIC CHUCK COLLET (REDUCTION SLEEVE : CLOSED TYPE)

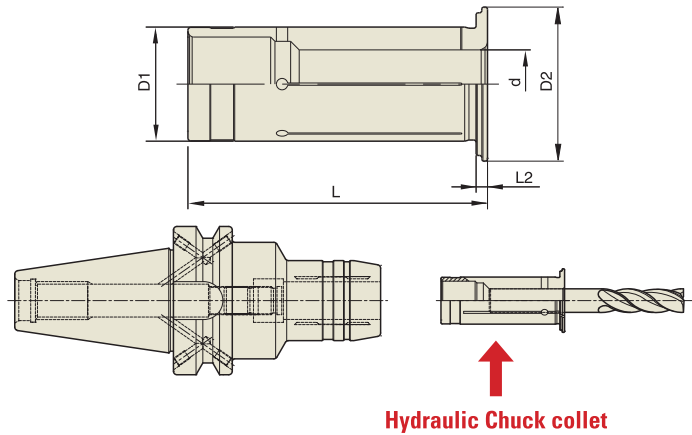

INCH / INCH

Unit : inch

EDP No.	TYPE	d	D1	D2	L	L2	
712108	HS1/2"	1/8"	0.125	0.500	0.748	1.850	0.079
712316		3/16"	0.188	0.500	0.748	1.850	0.079
712104		1/4"	0.250	0.500	0.748	1.850	0.079
712516		5/16"	0.313	0.500	0.748	1.850	0.079
725108	HS3/4"	1/8"	0.125	0.750	1.063	2.067	0.079
725316		3/16"	0.188	0.750	1.063	2.067	0.079
725104		1/4"	0.250	0.750	1.063	2.067	0.079
725516		5/16"	0.313	0.750	1.063	2.067	0.079
725308		3/8"	0.375	0.750	1.063	2.067	0.079
725102		1/2"	0.500	0.750	1.063	2.067	0.079
725508		5/8"	0.625	0.750	1.063	2.067	0.079
732108	HS1 1/4"	1/8"	0.125	1.250	1.535	2.500	0.118
732316		3/16"	0.188	1.250	1.535	2.500	0.118
732104		1/4"	0.250	1.250	1.535	2.500	0.118
732516		5/16"	0.313	1.250	1.535	2.500	0.118
732308		3/8"	0.375	1.250	1.535	2.500	0.118
732102		1/2"	0.500	1.250	1.535	2.500	0.118
732508		5/8"	0.625	1.250	1.535	2.500	0.118
732304		3/4"	0.750	1.250	1.535	2.500	0.118
732100		1	1.000	1.250	1.535	2.500	0.118

* Other special sizes of Hydraulic Chuck collets can be supplied on request.

Feature

The wall of Hydraulic Chuck collet(reduction sleeve) is cut by high precision wire-cutting to guarantee precise I.D and strong clamping power.

Chucking Method

Please assemble cutting tool with collet first, and then insert collet into Hydraulic Chuck.

HYDRAULIC CHUCK COLLET (REDUCTION SLEEVE : OPEN TYPE)

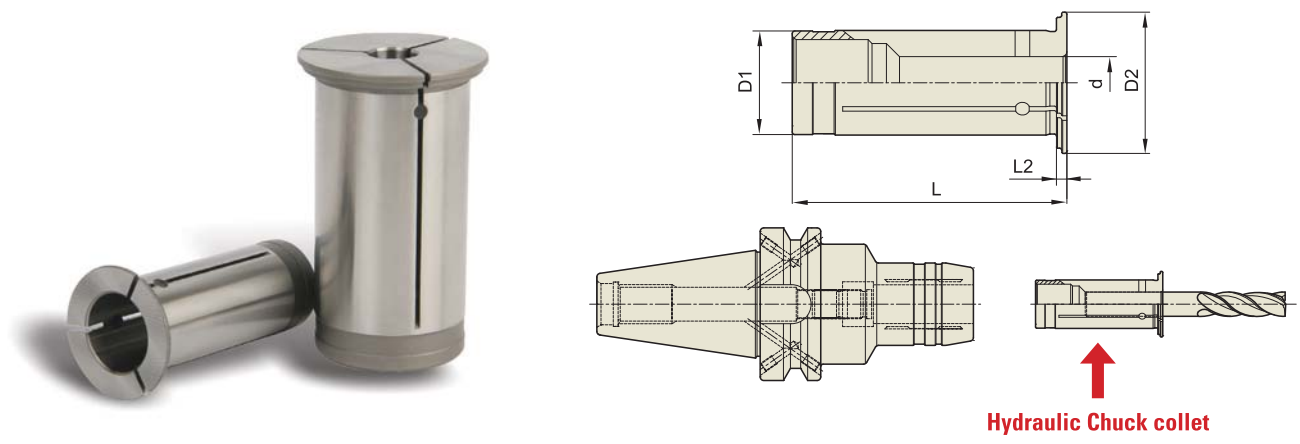

METRIC / METRIC

Unit : mm

EDP No.	TYPE	d	D1	D2	L	L2	
812030	HK12	3	12	19	47	2	
812040		4	12	19	47	2	
812050		5	12	19	47	2	
812060		6	12	19	47	2	
812070		7	12	19	47	2	
812008		8	12	19	47	2	
820030		HK20	3	20	27	52.5	2
820040			4	20	27	52.5	2
820050	5		20	27	52.5	2	
820060	6		20	27	52.5	2	
820070	7		20	27	52.5	2	
820080	8		20	27	52.5	2	
820090	9		20	27	52.5	2	
820100	10		20	27	52.5	2	
820110	11		20	27	52.5	2	
820120	12		20	27	52.5	2	
820130	13		20	27	52.5	2	
820140	14		20	27	52.5	2	
820150	15		20	27	52.5	2	
820160	16		20	27	52.5	2	
832060	HK32		6	32	39	63.5	3
832080			8	32	39	63.5	3
832100		10	32	39	63.5	3	
832120		12	32	39	63.5	3	
832140		14	32	39	63.5	3	
832160		16	32	39	63.5	3	
832180		18	32	39	63.5	3	
832200		20	32	39	63.5	3	
832250		25	32	39	63.5	3	

* Other special sizes of Hydraulic Chuck collets can be supplied on request.

- Feature** Hydraulic Chuck collet(reduction sleeve) is cut into trisection by high precision cutting to guarantee precise I.D and strong clamping power.
- Chucking Method** Please assemble cutting tool with collet first, and then insert collet into Hydraulic Chuck.

HYDRAULIC CHUCK COLLET (REDUCTION SLEEVE : CLOSED TYPE)

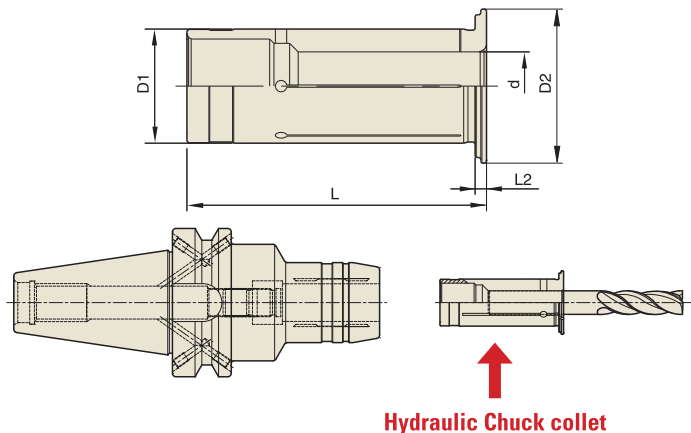

METRIC / METRIC

Unit : mm

EDP No.	TYPE	d	D1	D2	L	L2	
912030	HS12	3	12	19	47	2	
912040		4	12	19	47	2	
912050		5	12	19	47	2	
912060		6	12	19	47	2	
912070		7	12	19	47	2	
912080		8	12	19	47	2	
920030		HS20	3	20	27	52.5	2
920040			4	20	27	52.5	2
920050	5		20	27	52.5	2	
920060	6		20	27	52.5	2	
920070	7		20	27	52.5	2	
920080	8		20	27	52.5	2	
920090	9		20	27	52.5	2	
920100	10		20	27	52.5	2	
920110	11		20	27	52.5	2	
920120	12		20	27	52.5	2	
920130	13		20	27	52.5	2	
920140	14		20	27	52.5	2	
920150	15		20	27	52.5	2	
920160	16		20	27	52.5	2	
932060	HS32		6	32	39	63.5	3
932080			8	32	39	63.5	3
932100		10	32	39	63.5	3	
932120		12	32	39	63.5	3	
932140		14	32	39	63.5	3	
932160		16	32	39	63.5	3	
932180		18	32	39	63.5	3	
932200		20	32	39	63.5	3	
932250		25	32	39	63.5	3	

* Other special sizes of Hydraulic Chuck collets can be supplied on request.

Feature

The wall of Hydraulic Chuck collet(reduction sleeve) is cut by high precision wire-cutting to guarantee precise I.D and strong clamping power.

Chucking Method

Please assemble cutting tool with collet first, and then insert collet into Hydraulic Chuck.

HYDRAULIC CHUCK COLLET (REDUCTION SLEEVE : OPEN TYPE)

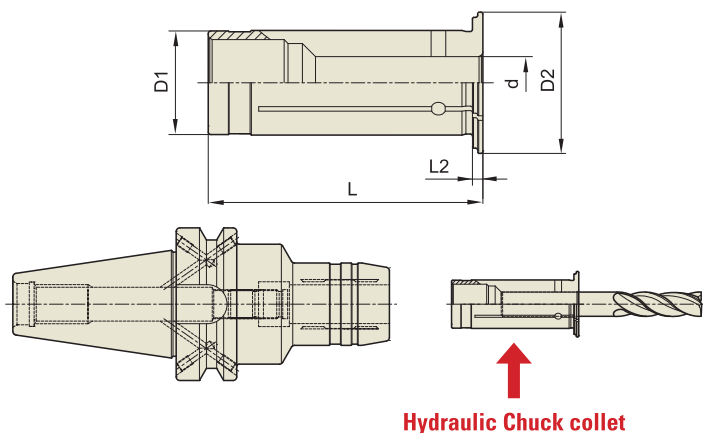

INCH / METRIC

Unit : inch

EDP No.	TYPE	d	D1	D2	L	L2	
101203	HK1/2"	3	3mm	0.500	0.748	1.850	0.079
101204		4	4mm	0.500	0.748	1.850	0.079
101205		5	5mm	0.500	0.748	1.850	0.079
101206		6	6mm	0.500	0.748	1.850	0.079
101208		8	8mm	0.500	0.748	1.850	0.079
102503	HK3/4"	3	3mm	0.750	1.063	2.067	0.079
102504		4	4mm	0.750	1.063	2.067	0.079
102505		5	5mm	0.750	1.063	2.067	0.079
102506		6	6mm	0.750	1.063	2.067	0.079
102508		8	8mm	0.750	1.063	2.067	0.079
102510		10	10mm	0.750	1.063	2.067	0.079
102512		12	12mm	0.750	1.063	2.067	0.079
102514		14	14mm	0.750	1.063	2.067	0.079
103208	HK1 1/4"	8	8mm	1.250	1.535	2.500	0.118
103210		10	10mm	1.250	1.535	2.500	0.118
103212		12	12mm	1.250	1.535	2.500	0.118
103214		14	14mm	1.250	1.535	2.500	0.118
103216		16	16mm	1.250	1.535	2.500	0.118
103218		18	18mm	1.250	1.535	2.500	0.118
103220		20	20mm	1.250	1.535	2.500	0.118
103225		25	25mm	1.250	1.535	2.500	0.118

* Other special sizes of Hydraulic Chuck collets can be supplied on request.

Feature

Hydraulic Chuck collet(reduction sleeve) is cut into trisection by high precision cutting to guarantee precise I.D and strong clamping power.

Chucking Method

Please assemble cutting tool with collet first, and then insert collet into Hydraulic Chuck.

HYDRAULIC CHUCK COLLET (REDUCTION SLEEVE : CLOSED TYPE)

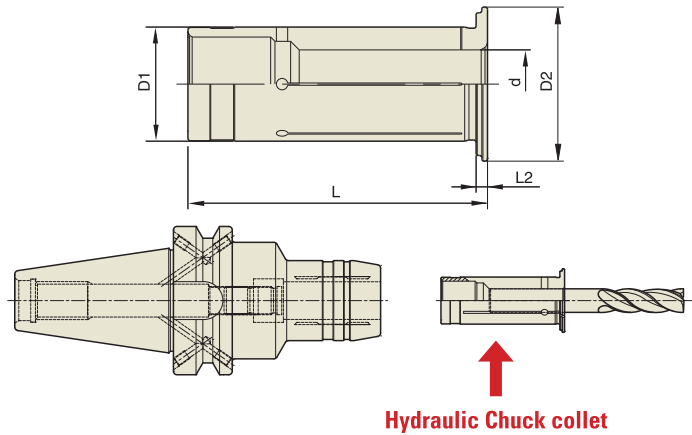

INCH / METRIC

Unit : inch

EDP No.	TYPE		d	D1	D2	L	L2
111203	HS1/2"	3	3mm	0.500	0.748	1.850	0.079
111204		4	4mm	0.500	0.748	1.850	0.079
111205		5	5mm	0.500	0.748	1.850	0.079
111206		6	6mm	0.500	0.748	1.850	0.079
111208		8	8mm	0.500	0.748	1.850	0.079
112503	HS3/4"	3	3mm	0.750	1.063	2.067	0.079
112504		4	4mm	0.750	1.063	2.067	0.079
112505		5	5mm	0.750	1.063	2.067	0.079
112506		6	6mm	0.750	1.063	2.067	0.079
112508		8	8mm	0.750	1.063	2.067	0.079
112510		10	10mm	0.750	1.063	2.067	0.079
112512		12	12mm	0.750	1.063	2.067	0.079
112514		14	14mm	0.750	1.063	2.067	0.079
113208	HS1 1/4"	8	8mm	1.250	1.535	2.500	0.118
113210		10	10mm	1.250	1.535	2.500	0.118
113212		12	12mm	1.250	1.535	2.500	0.118
113214		14	14mm	1.250	1.535	2.500	0.118
113216		16	16mm	1.250	1.535	2.500	0.118
113218		18	18mm	1.250	1.535	2.500	0.118
113220		20	20mm	1.250	1.535	2.500	0.118
113225		25	25mm	1.250	1.535	2.500	0.118

* Other special sizes of Hydraulic Chuck collets can be supplied on request.

Feature

The wall of Hydraulic Chuck collet(reduction sleeve) is cut by high precision wire-cutting to guarantee precise I.D and strong clamping power.

Chucking Method

Please assemble cutting tool with collet first, and then insert collet into Hydraulic Chuck.



ROTARY TOOLING

SHRINK FIT HOLDER



SHRINK FIT HOLDER

CAT : ASME B5.50-2009

BT : JIS B6339/MAS 403

DUAL CONTACT SHRINK FIT HOLDER

CCT : CAT DUAL CONTACT

CBT : BT DUAL CONTACT

HSK : DIN 69893/ISO 12164-1

SHRINK FIT EXTENSION

ST : STRAIGHT

SHRINK FIT HOLDER

CAT

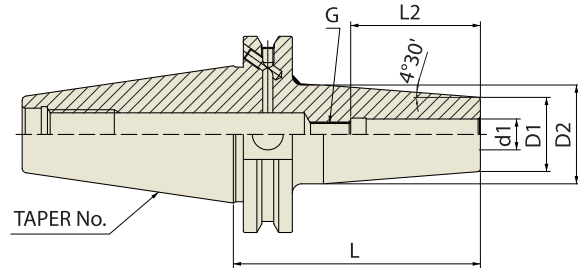

ASME B5.50 - CAT	Taper Accuracy AT3	G Value 2.5	RPM 25,000	Run-Out (at 3D) ≤0.00012"	Coolant System AD/B
---------------------	---------------------------------	-----------------------	----------------------	--	----------------------------------

ASME B5.50-2009-CAT

Unit : inch

EDP No.	TAPER No.	MODEL No.	d1	D1	D2	L	L2	G
VK020	40	CAT40AD/B-SFH1/8-3.15	0.125	0.394	0.748	3.150	0.354	-
VK022		CAT40AD/B-SFH3/16-3.15	0.188	0.394	0.748	3.150	0.472	-
VK024		CAT40AD/B-SFH1/4-3.15	0.250	0.827	1.063	3.150	1.417	M5x0.8mm
VK026		CAT40AD/B-SFH1/4-6.30	0.250	0.827	1.063	6.300	1.417	M5x0.8mm
VK028		CAT40AD/B-SFH3/8-3.15	0.375	0.945	1.260	3.150	1.654	M8x1.0mm
VK030		CAT40AD/B-SFH3/8-6.30	0.375	0.945	1.260	6.300	1.654	M8x1.0mm
VK032		CAT40AD/B-SFH1/2-3.15	0.500	0.945	1.260	3.150	1.811	M10x1.0mm
VK034		CAT40AD/B-SFH1/2-6.30	0.500	0.945	1.260	6.300	1.850	M10x1.0mm
VK036		CAT40AD/B-SFH5/8-3.15	0.625	1.063	1.339	3.150	1.969	M12x1.0mm
VK038		CAT40AD/B-SFH5/8-6.30	0.625	1.063	1.339	6.300	1.969	M12x1.0mm
VK040		CAT40AD/B-SFH3/4-3.15	0.750	1.299	1.654	3.150	2.047	M16x1.0mm
VK042		CAT40AD/B-SFH3/4-6.30	0.750	1.299	1.654	6.300	2.047	M16x1.0mm
VK044		CAT40AD/B-SFH1"-3.94	1.000	1.732	2.087	3.937	2.283	M16x1.0mm
VK046		CAT40AD/B-SFH1"-6.30	1.000	1.732	2.087	6.300	2.283	M16x1.0mm
VK048		CAT40AD/B-SFH 1 1/4-3.94	1.250	1.732	2.087	3.937	2.283	M16x1.0mm
VK050		CAT40AD/B-SFH 1 1/4-6.30	1.250	1.732	2.087	6.300	2.283	M16x1.0mm
VL020		50	CAT50AD/B-SFH1/8-3.15	0.125	0.394	0.748	3.150	0.354
VL022	CAT50AD/B-SFH3/16-3.15		0.188	0.394	0.748	3.150	0.472	-
VL024	CAT50AD/B-SFH1/4-3.15		0.250	0.827	1.063	3.150	1.417	M5x0.8mm
VL026	CAT50AD/B-SFH1/4-6.30		0.250	0.827	1.063	6.300	1.417	M5x0.8mm
VL028	CAT50AD/B-SFH3/8-3.15		0.375	0.945	1.260	3.150	1.575	M8x1.0mm
VL030	CAT50AD/B-SFH3/8-6.30		0.375	0.945	1.260	6.300	1.575	M8x1.0mm
VL032	CAT50AD/B-SFH1/2-3.15		0.500	0.945	1.260	3.150	1.850	M10x1.0mm
VL034	CAT50AD/B-SFH1/2-6.30		0.500	0.945	1.260	6.300	1.850	M10x1.0mm
VL036	CAT50AD/B-SFH5/8-3.15		0.625	1.063	1.339	3.150	1.969	M12x1.0mm
VL038	CAT50AD/B-SFH5/8-6.3		0.625	1.063	1.339	6.300	1.969	M12x1.0mm
VL040	CAT50AD/B-SFH3/4-3.15		0.750	1.299	1.654	3.150	2.047	M16x1.0mm
VL042	CAT50AD/B-SFH3/4-6.3		0.750	1.299	1.654	6.300	2.047	M16x1.0mm
VL044	CAT50AD/B-SFH1"-3.94		1.000	1.732	2.087	3.937	2.283	M16x1.0mm
VL046	CAT50AD/B-SFH1"-6.30		1.000	1.732	2.087	6.300	2.283	M16x1.0mm
VL048	CAT50AD/B-SFH 1 1/4-3.94		1.250	1.732	2.087	3.937	2.283	M16x1.0mm
VL050	CAT50AD/B-SFH 1 1/4-6.30		1.250	1.732	2.087	6.300	2.283	M16x1.0mm

SHRINK FIT HOLDER (COOLANT CHANNEL TYPE) **NEW**

CAT

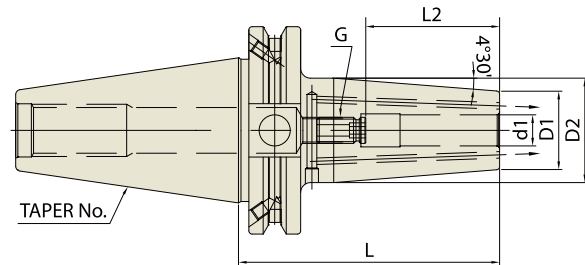

ASME B5.50 - CAT	Taper Accuracy AT3	G Value 2.5	RPM 25,000	Run-Out (at 3D) ≤0.00012"	Coolant System AD/B+C
------------------	------------------------------	-----------------------	----------------------	-------------------------------------	---------------------------------

ASME B5.50-2009-CAT

Unit : inch

EDP No.	TAPER No.	MODEL No.	d1	D1	D2	L	L2	G
VK028J	40	CAT40AD/B-SFH3/8C-3.15	0.375	0.945	1.260	3.150	1.654	M8x1.0mm
VK030J		CAT40AD/B-SFH3/8C-6.30	0.375	0.945	1.260	6.300	1.654	M8x1.0mm
VK032J		CAT40AD/B-SFH1/2C-3.15	0.500	0.945	1.260	3.150	1.850	M10x1.0mm
VK034J		CAT40AD/B-SFH1/2C-6.30	0.500	0.945	1.260	6.300	1.850	M10x1.0mm
VK036J		CAT40AD/B-SFH5/8C-3.15	0.625	1.063	1.339	3.150	1.969	M12x1.0mm
VK038J		CAT40AD/B-SFH5/8C-6.30	0.625	1.063	1.339	6.300	1.969	M12x1.0mm
VK040J		CAT40AD/B-SFH3/4C-3.15	0.750	1.299	1.654	3.150	2.047	M16x1.0mm
VK042J		CAT40AD/B-SFH3/4C-6.30	0.750	1.299	1.654	6.300	2.047	M16x1.0mm
VK044J		CAT40AD/B-SFH1C-3.94	1.000	1.732	2.087	3.940	2.283	M16x1.0mm
VK046J		CAT40AD/B-SFH1C-6.30	1.000	1.732	2.087	6.300	2.283	M16x1.0mm
VK048J		CAT40AD/B-SFH 1 1/4C-3.94	1.250	1.732	2.087	3.940	2.283	M16x1.0mm
VK050J		CAT40AD/B-SFH 1 1/4C-6.30	1.250	1.732	2.087	6.300	2.283	M16x1.0mm
VL028J	50	CAT50AD/B-SFH3/8C-3.15	0.375	0.945	1.260	3.150	1.575	M8x1.0mm
VL030J		CAT50AD/B-SFH3/8C-6.30	0.375	0.945	1.260	6.300	1.575	M8x1.0mm
VL032J		CAT50AD/B-SFH1/2C-3.15	0.500	0.945	1.260	3.150	1.850	M10x1.0mm
VL034J		CAT50AD/B-SFH1/2C-6.30	0.500	0.945	1.260	6.300	1.850	M10x1.0mm
VL036J		CAT50AD/B-SFH5/8C-3.15	0.625	1.063	1.339	3.150	1.969	M12x1.0mm
VL038J		CAT50AD/B-SFH5/8C-6.3	0.625	1.063	1.339	6.300	1.969	M12x1.0mm
VL040J		CAT50AD/B-SFH3/4C-3.15	0.750	1.299	1.654	3.150	2.047	M16x1.0mm
VL042J		CAT50AD/B-SFH3/4C-6.3	0.750	1.299	1.654	6.300	2.047	M16x1.0mm
VL044J		CAT50AD/B-SFH1C-3.94	1.000	1.732	2.087	3.940	2.283	M16x1.0mm
VL046J		CAT50AD/B-SFH1C-6.30	1.000	1.732	2.087	6.300	2.283	M16x1.0mm
VL048J		CAT50AD/B-SFH 1 1/4C-3.94	1.250	1.732	2.087	3.940	2.283	M16x1.0mm
VL050J		CAT50AD/B-SFH 1 1/4C-6.30	1.250	1.732	2.087	6.300	2.283	M16x1.0mm

* Effective cooling by coolant through cooling channel bores.

SHRINK FIT HOLDER

BT

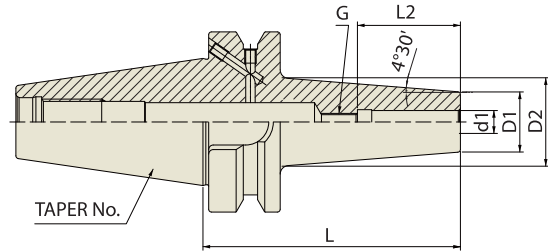

JIS B6339 -BT	Taper Accuracy AT3	G Value 2.5	RPM 25,000	Run-Out (at 3D) ≤0.00012"	Coolant System AD or AD/B
------------------	-----------------------	----------------	---------------	------------------------------	------------------------------

JIS B6339/MAS 403-BT

Unit : inch

EDP No.	TAPER No.	MODEL No.	d1	D1	D2	L	L2	G
VG020	30	BT30-SFH1/8-2.36	0.125	0.394	0.629	2.362	0.354	-
VG022		BT30-SFH3/16-2.36	0.188	0.394	0.629	2.362	0.472	-
VG024		BT30-SFH1/4-2.36	0.250	0.827	1.062	2.362	1.417	M5x0.8mm
VG026		BT30-SFH3/8-2.36	0.375	0.945	1.180	2.362	1.654	M8x1.0mm
VG028		BT30-SFH1/2-3.15	0.500	0.945	1.260	3.150	1.850	M10x1.0mm
VG030		BT30-SFH5/8-3.15	0.625	1.063	1.339	3.150	1.969	M12x1.0mm
VG032		BT30-SFH3/4-3.54	0.750	1.299	1.654	3.543	2.008	M16x1.0mm
VH020		40	BT40AD/B-SFH1/8-3.54	0.125	0.394	0.748	3.543	0.354
VH022	BT40AD/B-SFH3/16-3.54		0.188	0.394	0.748	3.543	0.472	-
VH024	BT40AD/B-SFH1/4-3.54		0.250	0.827	1.063	3.543	1.417	M5x0.8mm
VH026	BT40AD/B-SFH1/4-6.30		0.250	0.827	1.063	6.300	1.417	M5x0.8mm
VH028	BT40AD/B-SFH3/8-3.54		0.375	0.945	1.260	3.543	1.654	M8x1.0mm
VH030	BT40AD/B-SFH3/8-6.30		0.375	0.945	1.260	6.300	1.654	M8x1.0mm
VH032	BT40AD/B-SFH1/2-3.54		0.500	0.945	1.260	3.543	1.850	M10x1.0mm
VH034	BT40AD/B-SFH1/2-6.30		0.500	0.945	1.260	6.300	1.850	M10x1.0mm
VH036	BT40AD/B-SFH5/8-3.54		0.625	1.063	1.339	3.543	1.969	M12x1.0mm
VH038	BT40AD/B-SFH5/8-6.30		0.625	1.063	1.339	6.300	1.969	M12x1.0mm
VH040	BT40AD/B-SFH3/4-3.54		0.750	1.299	1.654	3.543	2.047	M16x1.0mm
VH042	BT40AD/B-SFH3/4-6.30		0.750	1.299	1.654	6.300	2.047	M16x1.0mm
VH044	BT40AD/B-SFH1"-3.94		1.000	1.732	2.087	3.937	2.283	M16x1.0mm
VH046	BT40AD/B-SFH1"-6.30		1.000	1.732	2.087	6.300	2.283	M16x1.0mm

SHRINK FIT HOLDER (COOLANT CHANNEL TYPE) **NEW**

BT

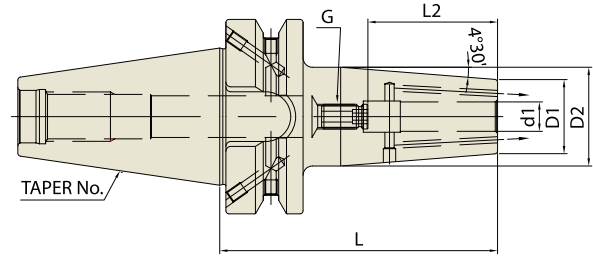

JIS B6339 -BT	Taper Accuracy AT3	G Value 2.5	RPM 25,000	Run-Out (at 3D) ≤0.00012"	Coolant System AD+C or AD/B+C
-------------------------	------------------------------	-----------------------	----------------------	-------------------------------------	---

JIS B6339/MAS 403-BT

Unit : inch

EDP No.	TAPER No.	MODEL No.	d1	D1	D2	L	L2	G
VG024J	30	BT30-SFH1/4C-2.36	0.250	0.827	1.063	2.360	1.417	M5x0.8mm
VG026J		BT30-SFH3/8C-2.36	0.375	0.945	1.180	2.360	1.654	M8x1.0mm
VG028J		BT30-SFH1/2C-3.15	0.500	0.945	1.260	3.150	1.850	M10x1.0mm
VG030J		BT30-SFH5/8C-3.15	0.625	1.063	1.339	3.150	1.969	M12x1.0mm
VG032J		BT30-SFH3/4C-3.54	0.750	1.299	1.654	3.540	2.008	M16x1.0mm
VH024J	40	BT40AD/B-SFH1/4C-3.54	0.250	0.827	1.063	3.540	1.417	M5x0.8mm
VH026J		BT40AD/B-SFH1/4C-6.30	0.250	0.827	1.063	6.300	1.417	M5x0.8mm
VH028J		BT40AD/B-SFH3/8C-3.54	0.375	0.945	1.260	3.540	1.654	M8x1.0mm
VH030J		BT40AD/B-SFH3/8C-6.30	0.375	0.945	1.260	6.300	1.654	M8x1.0mm
VH032J		BT40AD/B-SFH1/2C-3.54	0.500	0.945	1.260	3.540	1.850	M10x1.0mm
VH034J		BT40AD/B-SFH1/2C-6.30	0.500	0.945	1.260	6.300	1.850	M10x1.0mm
VH036J		BT40AD/B-SFH5/8C-3.54	0.625	1.063	1.339	3.540	1.969	M12x1.0mm
VH038J		BT40AD/B-SFH5/8C-6.30	0.625	1.063	1.339	6.300	1.969	M12x1.0mm
VH040J		BT40AD/B-SFH3/4C-3.54	0.750	1.299	1.654	3.540	2.047	M16x1.0mm
VH042J		BT40AD/B-SFH3/4C-6.30	0.750	1.299	1.654	6.300	2.047	M16x1.0mm
VH044J		BT40AD/B-SFH1C-3.94	1.000	1.732	2.087	3.940	2.283	M16x1.0mm
VH046J		BT40AD/B-SFH1C-6.30	1.000	1.732	2.087	6.300	2.283	M16x1.0mm

* Effective cooling by coolant through cooling channel bores.

DUAL CONTACT SHRINK FIT HOLDER

CCT

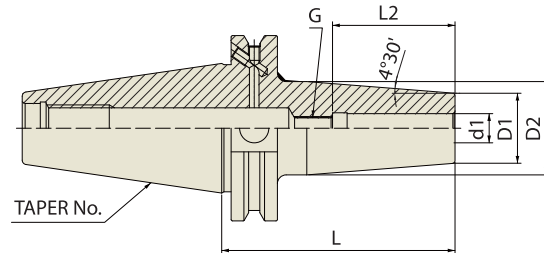

CCT	Taper Accuracy AT3	G Value 2.5	RPM 25,000	Run-Out (at 3D) ≤0.00012"	Coolant System AD/B
-----	------------------------------	-----------------------	----------------------	-------------------------------------	-------------------------------

CCT (CAT DUAL CONTACT)

Unit : inch

EDP No.	TAPER No.	MODEL No.	d1	D1	D2	L	L2	G
VB020	40	CCT40AD/B-SFH1/8-3.15	0.125	0.394	0.748	3.150	0.354	-
VB022		CCT40AD/B-SFH3/16-3.15	0.188	0.394	0.748	3.150	0.472	-
VB024		CCT40AD/B-SFH1/4-3.15	0.250	0.827	1.063	3.150	1.417	M5x0.8mm
VB026		CCT40AD/B-SFH1/4-6.30	0.250	0.827	1.063	6.300	1.417	M5x0.8mm
VB028		CCT40AD/B-SFH3/8-3.15	0.375	0.945	1.260	3.150	1.654	M8x1.0mm
VB030		CCT40AD/B-SFH3/8-6.30	0.375	0.945	1.260	6.300	1.654	M8x1.0mm
VB032		CCT40AD/B-SFH1/2-3.15	0.500	0.945	1.260	3.150	1.850	M10x1.0mm
VB034		CCT40AD/B-SFH1/2-6.30	0.500	0.945	1.260	6.300	1.850	M10x1.0mm
VB036		CCT40AD/B-SFH5/8-3.15	0.625	1.063	1.339	3.150	1.969	M12x1.0mm
VB038		CCT40AD/B-SFH5/8-6.30	0.625	1.063	1.339	6.300	1.969	M12x1.0mm
VB040		CCT40AD/B-SFH3/4-3.15	0.750	1.299	1.654	3.150	2.047	M16x1.0mm
VB042		CCT40AD/B-SFH3/4-6.30	0.750	1.299	1.654	6.300	2.047	M16x1.0mm
VB044		CCT40AD/B-SFH1"-3.94	1.000	1.732	2.087	3.937	2.283	M16x1.0mm
VB046		CCT40AD/B-SFH1"-6.30	1.000	1.732	2.087	6.300	2.283	M16x1.0mm
VB048		CCT40AD/B-SFH1 1/4-3.94	1.250	1.732	2.087	3.937	2.283	M16x1.0mm
VB050		CCT40AD/B-SFH1 1/4-6.30	1.250	1.732	2.087	6.300	2.283	M16x1.0mm
VC020	50	CCT50AD/B-SFH1/8-3.15	0.125	0.394	0.748	3.150	0.354	-
VC022		CCT50AD/B-SFH3/16-3.15	0.188	0.394	0.748	3.150	0.472	-
VC024		CCT50AD/B-SFH1/4-3.15	0.250	0.827	1.063	3.150	1.417	M5x0.8mm
VC026		CCT50AD/B-SFH1/4-6.30	0.250	0.827	1.063	6.300	1.417	M5x0.8mm
VC028		CCT50AD/B-SFH3/8-3.15	0.375	0.945	1.260	3.150	1.575	M8x1.0mm
VC030		CCT50AD/B-SFH3/8-6.30	0.375	0.945	1.260	6.300	1.575	M8x1.0mm
VC032		CCT50AD/B-SFH1/2-3.15	0.500	0.945	1.260	3.150	1.850	M10x1.0mm
VC034		CCT50AD/B-SFH1/2-6.30	0.500	0.945	1.260	6.300	1.850	M10x1.0mm
VC036		CCT50AD/B-SFH5/8-3.15	0.625	1.063	1.339	3.150	1.969	M12x1.0mm
VC040		CCT50AD/B-SFH5/8-6.30	0.625	1.063	1.339	6.300	1.969	M12x1.0mm
VC042		CCT50AD/B-SFH3/4-3.15	0.750	1.299	1.654	3.150	2.047	M16x1.0mm
VC044		CCT50AD/B-SFH3/4-6.30	0.750	1.299	1.654	6.300	2.047	M16x1.0mm
VC046		CCT50AD/B-SFH1"-3.94	1.000	1.732	2.087	3.937	2.283	M16x1.0mm
VC048		CCT50AD/B-SFH1"-6.30	1.000	1.732	2.087	6.300	2.283	M16x1.0mm
VC050		CCT50AD/B-SFH1 1/4-3.94	1.250	1.732	2.087	3.937	2.283	M16x1.0mm
VC052		CCT50AD/B-SFH1 1/4-6.30	1.250	1.732	2.087	6.300	2.283	M16x1.0mm

DUAL CONTACT SHRINK FIT HOLDER **NEW**

(COOLANT CHANNEL TYPE)

CCT

Shrink Fit Holder

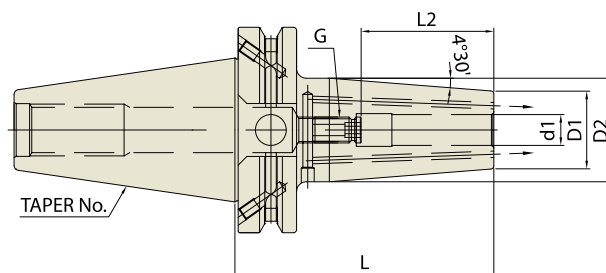

CCT	Taper Accuracy AT3	G Value 2.5	RPM 25,000	Run-Out (at 3D) ≤0.00012"	Coolant System AD/B+C
-----	------------------------------	-----------------------	----------------------	-------------------------------------	---------------------------------

CCT (CAT DUAL CONTACT)

Unit : inch

EDP No.	TAPER No.	MODEL No.	d1	D1	D2	L	L2	G	
VB024J	40	CCT40AD/B-SFH1/4C-3.15	0.250	0.827	1.063	3.150	1.417	M5x0.8mm	
VB026J		CCT40AD/B-SFH1/4C-6.30	0.250	0.827	1.063	6.300	1.417	M5x0.8mm	
VB028J		CCT40AD/B-SFH3/8C-3.15	0.375	0.945	1.260	3.150	1.654	M8x1.0mm	
VB030J		CCT40AD/B-SFH3/8C-6.30	0.375	0.945	1.260	6.300	1.654	M8x1.0mm	
VB032J		CCT40AD/B-SFH1/2C-3.15	0.500	0.945	1.260	3.150	1.850	M10x1.0mm	
VB034J		CCT40AD/B-SFH1/2C-6.30	0.500	0.945	1.260	6.300	1.850	M10x1.0mm	
VB036J		CCT40AD/B-SFH5/8C-3.15	0.625	1.063	1.339	3.150	1.969	M12x1.0mm	
VB038J		CCT40AD/B-SFH5/8C-6.30	0.625	1.063	1.339	6.300	1.969	M12x1.0mm	
VB040J		CCT40AD/B-SFH3/4C-3.15	0.750	1.299	1.654	3.150	2.047	M16x1.0mm	
VB042J		CCT40AD/B-SFH3/4C-6.30	0.750	1.299	1.654	6.300	2.047	M16x1.0mm	
VB044J		CCT40AD/B-SFH1C-3.94	1.000	1.732	2.087	3.940	2.283	M16x1.0mm	
VB046J		CCT40AD/B-SFH1C-6.30	1.000	1.732	2.087	6.300	2.283	M16x1.0mm	
VB048J		CCT40AD/B-SFH1 1/4C-3.94	1.250	1.732	2.087	3.940	2.283	M16x1.0mm	
VB050J		CCT40AD/B-SFH1 1/4C-6.30	1.250	1.732	2.087	6.300	2.283	M16x1.0mm	
VC024J		50	CCT50AD/B-SFH1/4C-3.15	0.250	0.827	1.063	3.150	1.417	M5x0.8mm
VC026J			CCT50AD/B-SFH1/4C-6.30	0.250	0.827	1.063	6.300	1.417	M5x0.8mm
VC028J	CCT50AD/B-SFH3/8C-3.15		0.375	0.945	1.260	3.150	1.654	M8x1.0mm	
VC030J	CCT50AD/B-SFH3/8C-6.30		0.375	0.945	1.260	6.300	1.654	M8x1.0mm	
VC032J	CCT50AD/B-SFH1/2C-3.15		0.500	0.945	1.260	3.150	1.850	M10x1.0mm	
VC034J	CCT50AD/B-SFH1/2C-6.30		0.500	0.945	1.260	6.300	1.850	M10x1.0mm	
VC036J	CCT50AD/B-SFH5/8C-3.15		0.625	1.063	1.339	3.150	1.969	M12x1.0mm	
VC040J	CCT50AD/B-SFH5/8C-6.30		0.625	1.063	1.339	6.300	1.969	M12x1.0mm	
VC042J	CCT50AD/B-SFH3/4C-3.15		0.750	1.299	1.654	3.150	2.047	M16x1.0mm	
VC044J	CCT50AD/B-SFH3/4C-6.30		0.750	1.299	1.654	6.300	2.047	M16x1.0mm	
VC046J	CCT50AD/B-SFH1C-3.94		1.000	1.732	2.087	3.940	2.283	M16x1.0mm	
VC048J	CCT50AD/B-SFH1C-6.30		1.000	1.732	2.087	6.300	2.283	M16x1.0mm	
VC050J	CCT50AD/B-SFH1 1/4C-3.94		1.250	1.732	2.087	3.940	2.283	M16x1.0mm	
VC052J	CCT50AD/B-SFH1 1/4C-6.30		1.250	1.732	2.087	6.300	2.283	M16x1.0mm	

* Effective cooling by coolant through cooling channel bores.

DUAL CONTACT SHRINK FIT HOLDER

CBT

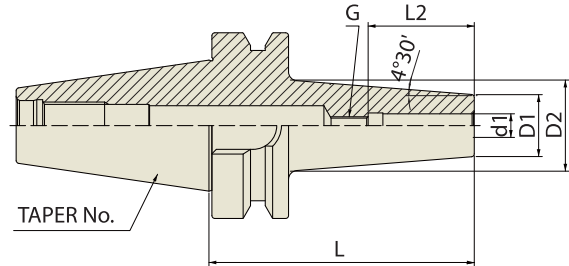

CBT	Taper Accuracy AT3	G Value 2.5	RPM 25,000	Run-Out (at 3D) ≤0.00012"	Coolant System AD
-----	------------------------------	-----------------------	----------------------	-------------------------------------	-----------------------------

CBT (BT DUAL CONTACT)

Unit : inch

EDP No.	TAPER No.	MODEL No.	d1	D1	D2	L	L2	G
VD020	30	CBT30-SFH1/8-2.36	0.125	0.394	0.629	2.362	0.354	-
VD022		CBT30-SFH3/16-2.36	0.188	0.394	0.629	2.362	0.472	-
VD024		CBT30-SFH1/4-2.36	0.250	0.827	1.062	2.362	1.417	M5x0.8mm
VD026		CBT30-SFH3/8-2.36	0.375	0.945	1.180	2.362	1.614	M8x1.0mm
VD028		CBT30-SFH1/2-3.15	0.500	0.945	1.260	3.150	1.850	M10x1.0mm
VD030		CBT30-SFH5/8-3.15	0.625	1.063	1.339	3.150	1.969	M12x1.0mm
VD032		CBT30-SFH3/4-3.54	0.750	1.299	1.654	3.543	2.047	M16x1.0mm
VE020		40	CBT40-SFH1/8-3.54	0.125	0.394	0.748	3.543	0.354
VE022	CBT40-SFH3/16-3.54		0.188	0.394	0.748	3.543	0.472	-
VE024	CBT40-SFH1/4-3.54		0.250	0.827	1.063	3.543	1.417	M5x0.8mm
VE026	CBT40-SFH1/4-6.30		0.250	0.827	1.063	6.300	1.417	M5x0.8mm
VE028	CBT40-SFH3/8-3.54		0.375	0.945	1.260	3.543	1.654	M8x1.0mm
VE030	CBT40-SFH3/8-6.30		0.375	0.945	1.260	6.300	1.654	M8x1.0mm
VE032	CBT40-SFH1/2-3.54		0.500	0.945	1.260	3.543	1.850	M10x1.0mm
VE034	CBT40-SFH1/2-6.30		0.500	0.945	1.260	6.300	1.850	M10x1.0mm
VE036	CBT40-SFH5/8-3.54		0.625	1.063	1.339	3.543	1.969	M12x1.0mm
VE038	CBT40-SFH5/8-6.30		0.625	1.063	1.339	6.300	1.969	M12x1.0mm
VE040	CBT40-SFH3/4-3.54		0.750	1.299	1.654	3.543	2.047	M16x1.0mm
VE042	CBT40-SFH3/4-6.30		0.750	1.299	1.654	6.300	2.047	M16x1.0mm
VE044	CBT40-SFH1"-3.94		1.000	1.732	2.087	3.937	2.283	M16x1.0mm
VE046	CBT40-SFH1"-6.30		1.000	1.732	2.087	6.300	2.283	M16x1.0mm

DUAL CONTACT SHRINK FIT HOLDER **NEW**

(COOLANT CHANNEL TYPE)

CBT

Shrink Fit Holder

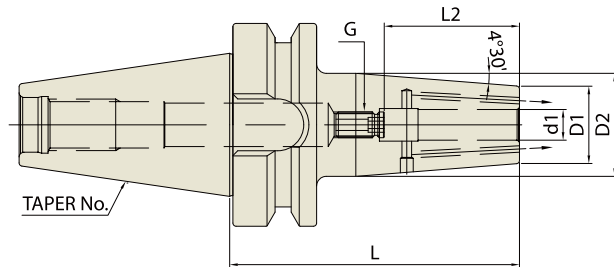

CBT	Taper Accuracy AT3	G Value 2.5	RPM 25,000	Run-Out (at 3D) ≤0.00012"	Coolant System AD+C
------------	------------------------------	-----------------------	----------------------	-------------------------------------	-------------------------------

CBT (BT DUAL CONTACT)

Unit : inch

EDP No.	TAPER No.	MODEL No.	d1	D1	D2	L	L2	G
VD024J	30	CBT30-SFH1/4C-2.36	0.250	0.827	1.062	2.360	1.417	M5x0.8mm
VD026J		CBT30-SFH3/8C-2.36	0.375	0.945	1.180	2.360	1.614	M8x1.0mm
VD028J		CBT30-SFH1/2C-3.15	0.500	0.945	1.260	3.150	1.850	M10x1.0mm
VD030J		CBT30-SFH5/8C-3.15	0.625	1.063	1.339	3.150	1.969	M12x1.0mm
VD032J		CBT30-SFH3/4C-3.54	0.750	1.299	1.654	3.540	2.047	M16x1.0mm
VE024J	40	CBT40-SFH1/4C-3.54	0.250	0.827	1.063	3.540	1.417	M5x0.8mm
VE026J		CBT40-SFH1/4C-6.30	0.250	0.827	1.063	6.300	1.417	M5x0.8mm
VE028J		CBT40-SFH3/8C-3.54	0.375	0.945	1.260	3.540	1.654	M8x1.0mm
VE030J		CBT40-SFH3/8C-6.30	0.375	0.945	1.260	6.300	1.654	M8x1.0mm
VE032J		CBT40-SFH1/2C-3.54	0.500	0.945	1.260	3.540	1.850	M10x1.0mm
VE034J		CBT40-SFH1/2C-6.30	0.500	0.945	1.260	6.300	1.850	M10x1.0mm
VE036J		CBT40-SFH5/8C-3.54	0.625	1.063	1.339	3.540	1.969	M12x1.0mm
VE038J		CBT40-SFH5/8C-6.30	0.625	1.063	1.339	6.300	1.969	M12x1.0mm
VE040J		CBT40-SFH3/4C-3.54	0.750	1.299	1.654	3.540	2.047	M16x1.0mm
VE042J		CBT40-SFH3/4C-6.30	0.750	1.299	1.654	6.300	2.047	M16x1.0mm
VE044J		CBT40-SFH1C-3.94	1.000	1.732	2.087	3.940	2.283	M16x1.0mm
VE046J		CBT40-SFH1C-6.30	1.000	1.732	2.087	6.300	2.283	M16x1.0mm

* Effective cooling by coolant through cooling channel bores.

DUAL CONTACT SHRINK FIT HOLDER

HSK

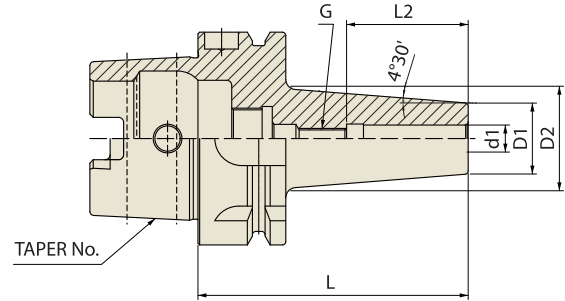

DIN 69893 - HSK	Taper Accuracy AT3	G Value 2.5	RPM 25,000	Run-Out (at 3D) ≤0.00012"	Coolant System AD
---------------------------	------------------------------	-----------------------	----------------------	-------------------------------------	-----------------------------

DIN 69893/ISO 12164-1-HSK FORM A

Unit : inch

EDP No.	TAPER No.	MODEL No.	d1	D1	D2	L	L2	G
VQ020	63A	HSK63A-SFH1/8-3.15	0.125	0.394	0.728	3.150	0.354	-
VQ022		HSK63A-SFH3/16-3.15	0.188	0.394	0.728	3.150	0.472	-
VQ024		HSK63A-SFH1/4-3.15	0.250	0.827	1.063	3.150	1.417	M5x0.8mm
VQ026		HSK63A-SFH1/4-6.30	0.250	0.827	1.063	6.300	1.417	M5x0.8mm
VQ028		HSK63A-SFH3/8-3.35	0.375	0.945	1.260	3.346	1.654	M8x1.0mm
VQ030		HSK63A-SFH3/8-6.30	0.375	0.945	1.260	6.300	1.654	M8x1.0mm
VQ032		HSK63A-SFH1/2-3.54	0.500	0.945	1.260	3.543	1.850	M10x1.0mm
VQ034		HSK63A-SFH1/2-6.30	0.500	0.945	1.260	6.300	1.850	M10x1.0mm
VQ036		HSK63A-SFH5/8-3.74	0.625	1.063	1.339	3.740	1.969	M12x1.0mm
VQ038		HSK63A-SFH5/8-6.30	0.625	1.063	1.339	6.300	1.969	M12x1.0mm
VQ040		HSK63A-SFH3/4-3.94	0.750	1.299	1.654	3.937	2.047	M16x1.0mm
VQ042		HSK63A-SFH3/4-6.30	0.750	1.299	1.654	6.300	2.047	M16x1.0mm
VQ046		HSK63A-SFH1"-4.53	1.000	1.732	2.087	4.528	2.283	M16x1.0mm
VQ048		HSK63A-SFH1"-6.30	1.000	1.732	2.087	6.300	2.283	M16x1.0mm
VR020	100A	HSK100A-SFH1/8-3.15	0.125	0.394	0.648	3.150	0.354	-
VR022		HSK100A-SFH3/16-3.15	0.188	0.394	0.648	3.150	0.472	-
VR023		HSK100A-SFH1/4-3.15	0,250	0.827	1.063	3.150	1.417	M5x0.8mm
VR024		HSK100A-SFH3/8-3.54	0.375	0.945	1.260	3.543	1.654	M8x1.0mm
VR026		HSK100A-SFH3/8-6.30	0.375	0.945	1.260	6.300	1.654	M8x1.0mm
VR028		HSK100A-SFH1/2-3.74	0.500	0.945	1.260	3.740	1.850	M10x1.0mm
VR030		HSK100A-SFH1/2-6.30	0.500	0.945	1.260	6.300	1.850	M10x1.0mm
VR032		HSK100A-SFH5/8-3.94	0.625	1.063	1.339	3.937	1.969	M12x1.0mm
VR034		HSK100A-SFH5/8-6.30	0.625	1.063	1.339	6.300	1.969	M12x1.0mm
VR036		HSK100A-SFH3/4-4.13	0.750	1.299	1.654	4.134	2.047	M16x1.0mm
VR038		HSK100A-SFH3/4-6.30	0.750	1.299	1.654	6.300	2.047	M16x1.0mm
VR040		HSK100A-SFH1"-4.53	1.000	1.732	2.087	4.528	2.283	M16x1.0mm
VR042		HSK100A-SFH1"-6.30	1.000	1.732	2.087	6.300	2.283	M16x1.0mm
VR044		HSK100A-SFH1 1/4-4.72	1.250	1.732	2.087	4.724	2.283	M16x1.0mm
VR046		HSK100A-SFH1 1/4"-6.30	1.250	1.732	2.087	6.300	2.283	M16x1.0mm

DUAL CONTACT SHRINK FIT HOLDER (COOLANT CHANNEL TYPE) **NEW**

HSK

Shrink Fit Holder

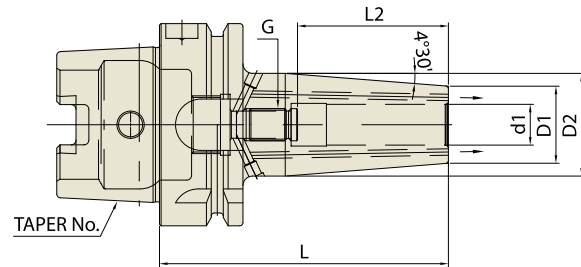

DIN 69893 - HSK	Taper Accuracy AT3	G Value 2.5	RPM 25,000	Run-Out (at 3D) ≤0.00012"	Coolant System AD+C
------------------------	------------------------------	-----------------------	----------------------	-------------------------------------	-------------------------------

DIN 69893/ISO 12164-1-HSK FORM A

Unit : inch

EDP No.	TAPER No.	MODEL No.	d1	D1	D2	L	L2	G	
VQ024J	63A	HSK63A-SFH1/4C-3.15	0.250	0.827	1.063	3.150	1.417	M5x0.8mm	
VQ026J		HSK63A-SFH1/4C-6.30	0.250	0.827	1.063	6.300	1.417	M5x0.8mm	
VQ028J		HSK63A-SFH3/8C-3.35	0.375	0.945	1.260	3.350	1.654	M8x1.0mm	
VQ030J		HSK63A-SFH3/8C-6.30	0.375	0.945	1.260	6.300	1.654	M8x1.0mm	
VQ032J		HSK63A-SFH1/2C-3.54	0.500	0.945	1.260	3.540	1.850	M10x1.0mm	
VQ034J		HSK63A-SFH1/2C-6.30	0.500	0.945	1.260	6.300	1.850	M10x1.0mm	
VQ036J		HSK63A-SFH5/8C-3.74	0.625	1.063	1.339	3.740	1.969	M12x1.0mm	
VQ038J		HSK63A-SFH5/8C-6.30	0.625	1.063	1.339	6.300	1.969	M12x1.0mm	
VQ040J		HSK63A-SFH3/4C-3.94	0.750	1.299	1.654	3.940	2.047	M16x1.0mm	
VQ042J		HSK63A-SFH3/4C-6.30	0.750	1.299	1.654	6.300	2.047	M16x1.0mm	
VQ046J		HSK63A-SFH1C-4.53	1.000	1.732	2.087	4.530	2.283	M16x1.0mm	
VQ048J		HSK63A-SFH1C-6.30	1.000	1.732	2.087	6.300	2.283	M16x1.0mm	
VR023J		100A	HSK100A-SFH1/4C-3.54	0.250	0.827	1.063	3.540	1.417	M5x0.8mm
VR024J			HSK100A-SFH3/8C-3.54	0.375	0.945	1.260	3.540	1.654	M8x1.0mm
VR026J	HSK100A-SFH3/8C-6.30		0.375	0.945	1.260	6.300	1.654	M8x1.0mm	
VR028J	HSK100A-SFH1/2C-3.74		0.500	0.945	1.260	3.740	1.850	M10x1.0mm	
VR030J	HSK100A-SFH1/2C-6.30		0.500	0.945	1.260	6.300	1.850	M10x1.0mm	
VR032J	HSK100A-SFH5/8C-3.94		0.625	1.063	1.339	3.940	1.969	M12x1.0mm	
VR034J	HSK100A-SFH5/8C-6.30		0.625	1.063	1.339	6.300	1.969	M12x1.0mm	
VR036J	HSK100A-SFH3/4C-4.13		0.750	1.299	1.654	4.130	2.047	M16x1.0mm	
VR038J	HSK100A-SFH3/4C-6.30		0.750	1.299	1.654	6.300	2.047	M16x1.0mm	
VR040J	HSK100A-SFH1C-4.53		1.000	1.732	2.087	4.530	2.283	M16x1.0mm	
VR042J	HSK100A-SFH1C-6.30		1.000	1.732	2.087	6.300	2.283	M16x1.0mm	
VR044J	HSK100A-SFH1 1/4C-4.72		1.250	1.732	2.087	4.720	2.283	M16x1.0mm	
VR046J	HSK100A-SFH1 1/4C-6.30		1.250	1.732	2.087	6.300	2.283	M16x1.0mm	

* Effective cooling by coolant through cooling channel bores.

SHRINK FIT EXTENSION

ST

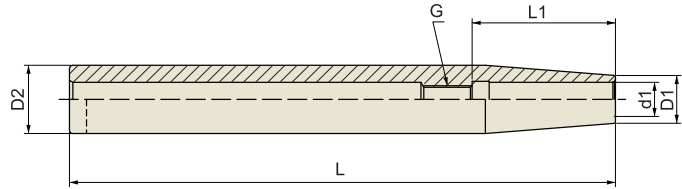

INCH

Unit : inch

EDP No.	TAPER No.	MODEL No.	d1	D1	D2	L	L1	G
VS010	ST1/2	ST1/2-SFH1/8-6.30	0.125	0.394	0.500	6.300	0.354	-
VS011		ST1/2-SFH3/16-6.30	0.188	0.394	0.500	6.300	0.472	-
VS012		ST1/2-SFH1/4-6.30	0.250	0.394	0.500	6.300	1.417	M5x0.8mm
VS020	ST5/8	ST5/8-SFH1/8-6.30	0.125	0.394	0.625	6.300	0.354	-
VS021		ST5/8-SFH3/16-6.30	0.188	0.394	0.625	6.300	0.472	-
VS022		ST5/8-SFH1/4-6.30	0.250	0.394	0.625	6.300	1.417	M5x0.8mm
VS023		ST5/8-SFH5/16-6.30	0.313	0.472	0.625	6.300	1.535	M6x1.0mm
VS030	ST3/4	ST3/4-SFH1/8-6.30	0.125	0.394	0.750	6.300	0.354	-
VS031		ST3/4-SFH3/16-6.30	0.188	0.394	0.750	6.300	0.472	-
VS032		ST3/4-SFH1/4-6.30	0.250	0.551	0.750	6.300	1.417	M5x0.8mm
VS033		ST3/4-SFH5/16-6.30	0.313	0.551	0.750	6.300	1.417	M6x1.0mm
VS034		ST3/4-SFH3/8-6.30	0.375	0.551	0.750	6.300	1.654	M8x1.0mm
VS035		ST3/4-SFH1/2-6.30	0.500	0.630	0.750	6.300	1.850	M10x1.0mm
VS040	ST1	ST1-SFH1/8-6.30	0.125	0.394	1.000	6.300	0.354	-
VS041		ST1-SFH3/16-6.30	0.188	0.394	1.000	6.300	0.472	-
VS042		ST1-SFH1/4-6.30	0.250	0.551	1.000	6.300	1.417	M5x0.8mm
VS043		ST1-SFH5/16-6.30	0.313	0.551	1.000	6.300	1.417	M6x1.0mm
VS044		ST1-SFH3/8-6.30	0.375	0.787	1.000	6.300	1.654	M8x1.0mm
VS045		ST1-SFH1/2-6.30	0.500	0.787	1.000	6.300	1.850	M10x1.0mm
VS046		ST1-SFH5/8-6.30	0.625	0.866	1.000	6.300	1.929	M12x1.0mm
VS050	ST1-1/4	ST1-1/4-SFH1/8-6.30	0.125	0.394	1.250	6.300	0.354	-
VS051		ST1-1/4-SFH3/16-6.30	0.188	0.394	1.250	6.300	0.472	-
VS052		ST1-1/4-SFH1/4-6.30	0.250	0.551	1.250	6.300	1.417	M5x0.8mm
VS053		ST1-1/4-SFH5/16-6.30	0.313	0.551	1.250	6.300	1.417	M6x1.0mm
VS054		ST1-1/4-SFH3/8-6.30	0.375	0.945	1.250	6.300	1.654	M8x1.0mm
VS055		ST1-1/4-SFH1/2-6.30	0.500	0.945	1.250	6.300	1.850	M10x1.0mm
VS056		ST1-1/4-SFH5/8-6.30	0.625	1.063	1.250	6.300	1.929	M12x1.0mm
VS057		ST1-1/4-SFH3/4-6.30	0.750	1.063	1.250	6.300	2.008	M16x1.0mm

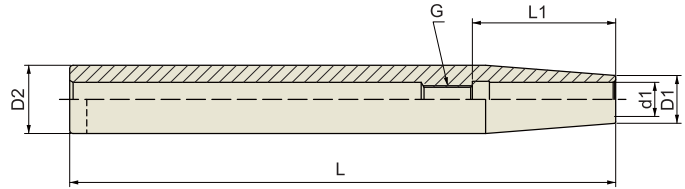

METRIC (STANDARD)

Unit : mm

EDP No.	TAPER No.	MODEL No.	d1	D1	D2	L	L1	G
VS010M	12	ST12-SFH3-120	3	8	12	120	10	-
VS011M		ST12-SFH4-120	4	8	12	120	12	-
VS012M		ST12-SFH5-120	5	10	12	120	15	-
VS013M		ST12-SFH6-120	6	10	12	120	36	M5×0.8
VS020M	16	ST16-SFH3-120	3	10	16	120	10	-
VS021M		ST16-SFH4-120	4	10	16	120	12	-
VS022M		ST16-SFH5-120	5	10	16	120	15	-
VS023M		ST16-SFH6-120	6	10	16	120	36	M5×0.8
VS024M		ST16-SFH8-120	8	12	16	120	36	M6×1.0
VS030M	20	ST20-SFH3-120	3	10	20	120	10	-
VS031M		ST20-SFH4-120	4	10	20	120	12	-
VS032M		ST20-SFH5-120	5	10	20	120	15	-
VS033M		ST20-SFH6-120	6	10	20	120	36	M5×0.8
VS034M		ST20-SFH8-120	8	12	20	120	36	M6×1.0
VS035M		ST20-SFH10-120	10	14	20	120	41.5	M8×1.0
VS036M		ST20-SFH12-120	12	16	20	120	46	M10×1.0

SHRINK FIT EXTENSION

ST

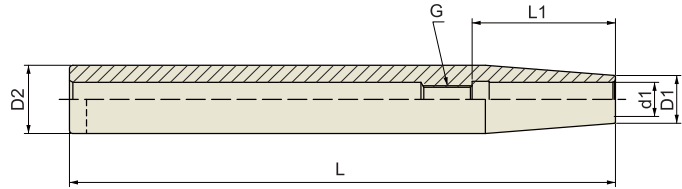

METRIC (EXTENDED)

Unit : mm

EDP No.	TAPER No.	MODEL No.	d1	D1	D2	L	L1	G
VS110M	12	ST12-SFH3-160	3	8	12	160	10	-
VS111M		ST12-SFH4-160	4	8	12	160	12	-
VS112M		ST12-SFH5-160	5	10	12	160	15	-
VS113M		ST12-SFH6-160	6	10	12	160	36	M5×0.8
VS210M	16	ST16-SFH3-160	3	10	16	160	10	-
VS211M		ST16-SFH4-160	4	10	16	160	12	-
VS212M		ST16-SFH5-160	5	10	16	160	15	-
VS213M		ST16-SFH6-160	6	10	16	160	36	M5×0.8
VS214M		ST16-SFH8-160	8	12	16	160	36	M6×1.0
VS310M	20	ST20-SFH3-160	3	10	20	160	10	-
VS311M		ST20-SFH4-160	4	10	20	160	12	-
VS312M		ST20-SFH5-160	5	10	20	160	15	-
VS313M		ST20-SFH6-160	6	10	20	160	36	M5×0.8
VS314M		ST20-SFH8-160	8	12	20	160	36	M6×1.0
VS315M		ST20-SFH10-160	10	14	20	160	41.5	M8×1.0
VS316M		ST20-SFH12-160	12	16	20	160	46	M10×1.0
VS410M	25	ST25-SFH3-160	3	10	25	160	10	-
VS411M		ST25-SFH4-160	4	10	25	160	12	-
VS412M		ST25-SFH5-160	5	15	25	160	15	-
VS413M		ST25-SFH6-160	6	20	25	160	36	M5×0.8
VS414M		ST25-SFH8-160	8	20	25	160	36	M6×1.0
VS415M		ST25-SFH10-160	10	20	25	160	41.5	M8×1.0
VS416M		ST25-SFH12-160	12	20	25	160	46	M10×1.0
VS417M		ST25-SFH14-160	14	20	25	160	46	M10×1.0
VS418M	ST25-SFH16-160	16	22	25	160	49	M12×1.0	
VS510M	32	ST32-SFH6-160	6	20	32	160	36	M5×0.8
VS511M		ST32-SFH8-160	8	20	32	160	36	M6×1.0
VS512M		ST32-SFH10-160	10	24	32	160	41.5	M8×1.0
VS513M		ST32-SFH12-160	12	24	32	160	46	M10×1.0
VS514M		ST32-SFH14-160	14	27	32	160	46	M10×1.0
VS515M		ST32-SFH16-160	16	27	32	160	49	M12×1.0
VS516M		ST32-SFH18-160	18	27	32	160	49	M12×1.0
VS517M	ST32-SFH20-160	20	27	32	160	51	M16×1.0	



ROTARY TOOLING

END MILL HOLDER & SIDE LOCK ARBOR



END MILL HOLDER

CAT : ASME B5.50-2009

BT : JIS B6339/MAS 403

DUAL CONTACT SIDE LOCK ARBOR

CCT : CAT DUAL CONTACT

CBT : BT DUAL CONTACT

DUAL CONTACT END MILL HOLDER

HSK : DIN 69893/ISO 12164-1

- COOLANT CHANNEL TYPE

END MILL HOLDER

CAT

End Mill Holder
& Side Lock Arbor

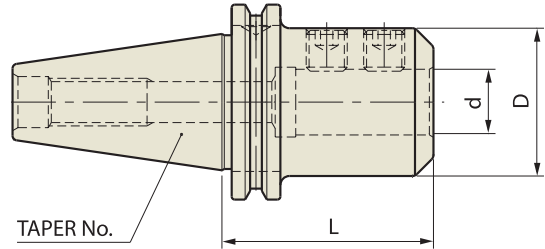

ASME B5.50 -CAT	Taper Accuracy AT3	G Value 6.3	RPM 15,000	Coolant System AD
--------------------	--------------------------	----------------	---------------	-------------------------

ASME B5.50-2009-CAT

■ STUB

Unit : inch

EDP No.	TAPER No.	MODEL No.	d	D	L
AK206	40	CAT40-EMH1/2-1.75	0.500	1.25	1.75
AK208		CAT40-EMH5/8-1.75	0.625	1.50	1.75
AK210		CAT40-EMH3/4-1.75	0.750	1.75	1.75
AK214		CAT40-EMH1"-1.75	1.000	1.75	1.75
AK217		CAT40-EMH1 1/4-2.00	1.250	2.25	2.00

* High balanced End Mill Holders on page 56~57.

* Set screws for End Mill Holders on page 65.

END MILL HOLDER

CAT

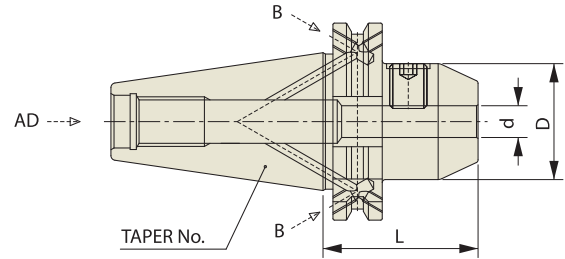

End Mill Holder
& Side Lock Arbor

ASME B5.50-2009-CAT

ASME B5.50 - CAT	Taper Accuracy AT3	G Value 6.3	RPM 15,000	Coolant System AD/B
---------------------	---------------------------------	-----------------------	----------------------	----------------------------------

STANDARD

Unit : inch

EDP No.	TAPER No.	MODEL No.	d	D	L
AK000B	40	CAT40AD/B-EMH1/8-2.50	0.125	0.69	2.50
AK001B		CAT40AD/B-EMH3/16-2.50	0.187	0.69	2.50
AK002B		CAT40AD/B-EMH1/4-2.50	0.250	0.78	2.50
AK003B		CAT40AD/B-EMH5/16-2.50	0.312	0.88	2.50
AK004B		CAT40AD/B-EMH3/8-2.50	0.375	1.00	2.50
AK005B		CAT40AD/B-EMH7/16-2.50	0.437	1.13	2.50
AK006B		CAT40AD/B-EMH1/2-2.63	0.500	1.25	2.63
AK008B		CAT40AD/B-EMH5/8-3.75	0.625	1.50	3.75
AK010B		CAT40AD/B-EMH3/4-3.75	0.750	1.75	3.75
AK012B		CAT40AD/B-EMH7/8-4.00	0.875	1.88	4.00
AK014B		CAT40AD/B-EMH1"-4.00	1.000	2.00	4.00
AK017B		CAT40AD/B-EMH1 1/4-4.25	1.250	2.50	4.25
AK021B		CAT40AD/B-EMH1 1/2-4.63	1.500	2.50	4.63
AL002B		50	CAT50AD/B-EMH1/4-2.50	0.250	0.78
AL003B	CAT50AD/B-EMH5/16-2.50		0.312	0.88	2.50
AL004B	CAT50AD/B-EMH3/8-2.50		0.375	1.00	2.50
AL005B	CAT50AD/B-EMH7/16-2.63		0.437	1.13	2.63
AL006B	CAT50AD/B-EMH1/2-2.63		0.500	1.25	2.63
AL008B	CAT50AD/B-EMH5/8-3.75		0.625	1.50	3.75
AL010B	CAT50AD/B-EMH3/4-3.75		0.750	1.75	3.75
AL012B	CAT50AD/B-EMH7/8-3.75		0.875	1.88	3.75
AL014B	CAT50AD/B-EMH1"-4.00		1.000	2.00	4.00
AL017B	CAT50AD/B-EMH1 1/4-4.00		1.250	2.50	4.00
AL021B	CAT50AD/B-EMH1 1/2-4.00		1.500	2.50	4.00
AL029B	CAT50AD/B-EMH2"-5.63		2.000	3.75	5.63

* High balanced End Mill Holders are available on request.

* Set screws for End Mill Holders on page 65.

END MILL HOLDER

CAT

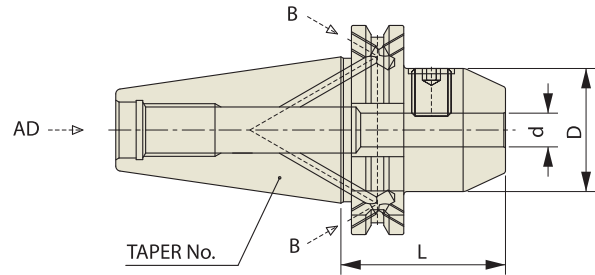

ASME B5.50
- CAT

Taper
Accuracy
AT3

G Value
6.3

RPM
15,000

Coolant
System
AD/B

ASME B5.50-2009-CAT

■ EXTENDED

Unit : inch

EDP No.	TAPER No.	MODEL No.	d	D	L	
AK104B	40	CAT40AD/B-EMH3/8-4.50	0.375	1.00	4.50	
AK106B		CAT40AD/B-EMH1/2-4.63	0.500	1.25	4.63	
AK108B		CAT40AD/B-EMH5/8-5.75	0.625	1.50	5.75	
AK110B		CAT40AD/B-EMH3/4-5.75	0.750	1.75	5.75	
AK112B		CAT40AD/B-EMH7/8-6.00	0.875	1.88	6.00	
AK114B		CAT40AD/B-EMH1"-6.00	1.000	2.00	6.00	
AK117B		CAT40AD/B-EMH1 1/4-6.25	1.250	2.50	6.25	
AK121B		CAT40AD/B-EMH1 1/2-6.63	1.500	2.50	6.63	
AL104B		50	CAT50AD/B-EMH3/8-4.50	0.375	1.00	4.50
AL106B			CAT50AD/B-EMH1/2-4.63	0.500	1.25	4.63
AL108B	CAT50AD/B-EMH5/8-5.75		0.625	1.50	5.75	
AL110B	CAT50AD/B-EMH3/4-5.75		0.750	1.75	5.75	
AL112B	CAT50AD/B-EMH7/8-5.75		0.875	1.88	5.75	
AL114B	CAT50AD/B-EMH1"-6.00		1.000	2.00	6.00	
AL117B	CAT50AD/B-EMH1 1/4-6.00		1.250	2.50	6.00	
AL121B	CAT50AD/B-EMH1 1/2-6.00		1.500	2.50	6.00	
AL129B	CAT50AD/B-EMH2"-7.63		2.000	3.75	7.63	

* High balanced End Mill Holders are available on request.

* Set screws for End Mill Holders on page 65.

END MILL HOLDER (COOLANT CHANNEL TYPE)

CAT

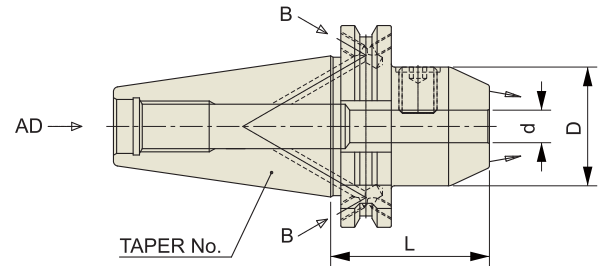

ASME B5.50 - CAT	Taper Accuracy AT3	G Value 6.3	RPM 15,000	Coolant System AD/B+C
---------------------	--------------------------	----------------	---------------	-----------------------------

ASME B5.50-2009-CAT

Unit : inch

EDP No.	TAPER No.	MODEL No.	d	D	L
AK002C	40	CAT40AD/B-EMH1/4C-1.97	0.250	0.780	1.969
AK003C		CAT40AD/B-EMH5/16C-1.97	0.313	0.880	1.969
AK004C		CAT40AD/B-EMH3/8C-1.97	0.375	1.000	1.969
AK005C		CAT40AD/B-EMH1/2C-1.97	0.500	1.250	1.969
AK008C		CAT40AD/B-EMH5/8C-2.48	0.625	1.500	2.480
AK010C		CAT40AD/B-EMH3/4C-2.48	0.750	1.750	2.480
AK012C		CAT40AD/B-EMH1C-3.94	1.000	2.000	3.937
AK017C		CAT40AD/B-EMH1 1/4C-3.94	1.250	2.500	3.937
AL002C		50	CAT50AD/B-EMH1/4C-2.48	0.250	0.780
AL003C	CAT50AD/B-EMH5/16C-2.48		0.313	0.880	2.480
AL004C	CAT50AD/B-EMH3/8C-2.48		0.375	1.000	2.480
AL005C	CAT50AD/B-EMH1/2C-2.48		0.500	1.250	2.480
AL008C	CAT50AD/B-EMH5/8C-2.48		0.625	1.500	2.480
AL010C	CAT50AD/B-EMH3/4C-2.48		0.750	1.750	2.480
AL012C	CAT50AD/B-EMH1C-3.15		1.000	2.000	3.150
AL017C	CAT50AD/B-EMH1 1/4C-3.94		1.250	2.500	3.937

- * High balanced End Mill Holders are available on request.
- * Set screws for End Mill Holders on page 65.

HIGH BALANCED END MILL HOLDER

CAT

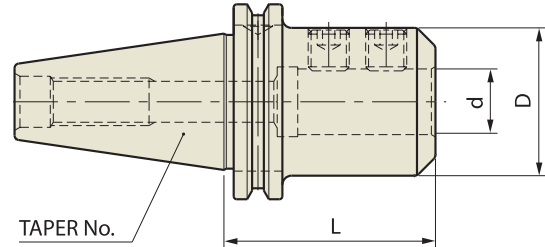

ASME B5.50
- CAT

Taper
Accuracy
AT3

G Value
2.5

RPM
25,000

Coolant
System
AD

ASME B5.50-2009-CAT

■ STUB

Unit : inch

EDP No.	TAPER No.	MODEL No.	d	D	L
AK206B25	40	CAT40-EMH1/2-1.75	0.500	1.25	1.75
AK208B25		CAT40-EMH5/8-1.75	0.625	1.50	1.75
AK210B25		CAT40-EMH3/4-1.75	0.750	1.75	1.75
AK214B25		CAT40-EMH1"-1.75	1.000	1.75	1.75
AK217B25		CAT40-EMH1 1/4-2.00	1.250	2.25	2.00

■ STANDARD

Unit : inch

EDP No.	TAPER No.	MODEL No.	d	D	L	
AK000B25	40	CAT40-EMH1/8-2.50	0.125	0.69	2.50	
AK001B25		CAT40-EMH3/16-2.50	0.187	0.69	2.50	
AK002B25		CAT40-EMH1/4-2.50	0.250	0.78	2.50	
AK003B25		CAT40-EMH5/16-2.50	0.312	0.88	2.50	
AK004B25		CAT40-EMH3/8-2.50	0.375	1.00	2.50	
AK005B25		CAT40-EMH7/16-2.50	0.437	1.13	2.50	
AK006B25		CAT40-EMH1/2-2.63	0.500	1.25	2.63	
AK008B25		CAT40-EMH5/8-3.75	0.625	1.50	3.75	
AK010B25		CAT40-EMH3/4-3.75	0.750	1.75	3.75	
AK012B25		CAT40-EMH7/8-4.00	0.875	1.88	4.00	
AK014B25		CAT40-EMH1"-4.00	1.000	2.00	4.00	
AK017B25		CAT40-EMH1 1/4-4.25	1.250	2.50	4.25	
AK021B25		CAT40-EMH1 1/2-4.63	1.500	2.50	4.63	
AL002B25		50	CAT50-EMH1/4-2.50	0.250	0.78	2.50
AL003B25			CAT50-EMH5/16-2.50	0.312	0.88	2.50
AL004B25			CAT50-EMH3/8-2.50	0.375	1.00	2.50
AL005B25			CAT50-EMH7/16-2.63	0.437	1.13	2.63
AL006B25	CAT50-EMH1/2-2.63		0.500	1.25	2.63	
AL008B25	CAT50-EMH5/8-3.75		0.625	1.50	3.75	
AL010B25	CAT50-EMH3/4-3.75		0.750	1.75	3.75	
AL012B25	CAT50-EMH7/8-3.75		0.875	1.88	3.75	
AL014B25	CAT50-EMH1"-4.00		1.000	2.00	4.00	
AL017B25	CAT50-EMH1 1/4-4.00		1.250	2.50	4.00	
AL021B25	CAT50-EMH1 1/2-4.00		1.500	2.50	4.00	
AL029B25	CAT50-EMH2"-5.63		2.000	3.75	5.63	

* Set screws for End Mill Holders on page 65.

HIGH BALANCED END MILL HOLDER

CAT

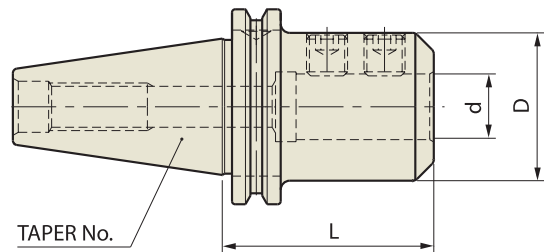

End Mill Holder
& Side Lock Arbor

ASME B5.50-2009-CAT

ASME B5.50 - CAT	Taper Accuracy AT3	G Value 2.5	RPM 25,000	Coolant System AD
---------------------	--------------------------	----------------	---------------	-------------------------

■ EXTENDED

Unit : inch

EDP No.	TAPER No.	MODEL No.	d	D	L	
AK104B25	40	CAT40-EMH3/8-4.50	0.375	1.00	4.50	
AK106B25		CAT40-EMH1/2-4.63	0.500	1.25	4.63	
AK108B25		CAT40-EMH5/8-5.75	0.625	1.50	5.75	
AK110B25		CAT40-EMH3/4-5.75	0.750	1.75	5.75	
AK112B25		CAT40-EMH7/8-6.00	0.875	1.88	6.00	
AK114B25		CAT40-EMH1"-6.00	1.000	2.00	6.00	
AK117B25		CAT40-EMH1 1/4-6.25	1.250	2.50	6.25	
AK121B25		CAT40-EMH1 1/2-6.63	1.500	2.50	6.63	
AL104B25		50	CAT50-EMH3/8-4.50	0.375	1.00	4.50
AL106B25			CAT50-EMH1/2-4.63	0.500	1.25	4.63
AL108B25	CAT50-EMH5/8-5.75		0.625	1.50	5.75	
AL110B25	CAT50-EMH3/4-5.75		0.750	1.75	5.75	
AL112B25	CAT50-EMH7/8-5.75		0.875	1.88	5.75	
AL114B25	CAT50-EMH1"-6.00		1.000	2.00	6.00	
AL117B25	CAT50-EMH1 1/4-6.00		1.250	2.50	6.00	
AL121B25	CAT50-EMH1 1/2-6.00		1.500	2.50	6.00	
AL129B25	CAT50-EMH2"-7.63		2.000	3.75	7.63	

* Set screws for End Mill Holders on page 65.

END MILL HOLDER

BT

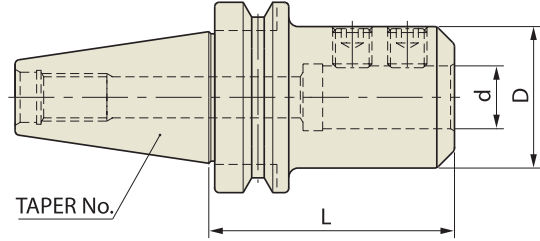

JIS B6339 -BT	Taper Accuracy AT3	G Value 6.3	RPM 15,000	Coolant System AD
------------------	--------------------------	----------------	---------------	-------------------------

JIS B6339/MAS 403-BT

■ STUB

Unit : inch

EDP No.	TAPER No.	MODEL No.	d	D	L
AH206	40	BT40-EMH1/2-1.25	0.500	1.25	1.25
AH208		BT40-EMH5/8-1.38	0.625	1.50	1.38
AH210		BT40-EMH3/4-1.44	0.750	1.75	1.44
AH214		BT40-EMH1"-2.50	1.000	2.00	2.50
AH217		BT40-EMH1 1/4-2.50	1.250	2.50	2.50

■ STANDARD

Unit : inch

EDP No.	TAPER No.	MODEL No.	d	D	L
AI002	50	BT50-EMH1/4-3.00	0.250	0.78	3.00
AI004		BT50-EMH3/8-3.00	0.375	1.00	3.00
AI006		BT50-EMH1/2-3.00	0.500	1.25	3.00
AI008		BT50-EMH5/8-3.00	0.625	1.50	3.00
AI010		BT50-EMH3/4-3.00	0.750	1.75	3.00
AI012		BT50-EMH7/8-4.00	0.875	1.88	4.00
AI014		BT50-EMH1"-4.25	1.000	2.00	4.25
AI017		BT50-EMH1 1/4-4.25	1.250	2.50	4.25
AI021		BT50-EMH1 1/2-4.25	1.500	2.50	4.25
AI029		BT50-EMH2"-5.00	2.000	3.75	5.00

■ EXTENDED

Unit : inch

EDP No.	TAPER No.	MODEL No.	d	D	L
AI104	50	BT50-EMH3/8-6.00	0.375	1.00	6.00
AI106		BT50-EMH1/2-6.00	0.500	1.25	6.00
AI108		BT50-EMH5/8-6.00	0.625	1.50	6.00
AI110		BT50-EMH3/4-6.00	0.750	1.75	6.00
AI112		BT50-EMH7/8-6.00	0.875	1.88	6.00
AI114		BT50-EMH1"-6.00	1.000	2.00	6.00
AI117		BT50-EMH1 1/4-6.00	1.250	2.50	6.00
AI121		BT50-EMH1 1/2-6.00	1.500	2.50	6.00
AI129		BT50-EMH2"-6.00	2.000	3.75	6.00

* High balanced End Mill Holders on page 61~62.

* Set screws for End Mill Holders on page 65.

END MILL HOLDER

BT

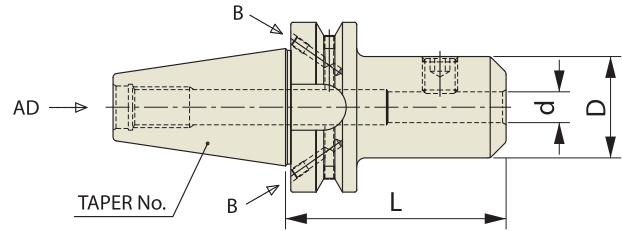

JIS B6339 -BT	Taper Accuracy AT3	G Value 6.3	RPM 15,000	Coolant System AD/B
------------------	--------------------------	----------------	---------------	---------------------------

JIS B6339/MAS 403-BT

STANDARD

Unit : inch

EDP No.	TAPER No.	MODEL No.	d	D	L
AH000B	40	BT40AD/B-EMH1/8-2.50	0.125	0.69	2.50
AH001B		BT40AD/B-EMH3/16-2.50	0.187	0.69	2.50
AH002B		BT40AD/B-EMH1/4-2.50	0.250	0.78	2.50
AH003B		BT40AD/B-EMH5/16-2.50	0.312	0.88	2.50
AH004B		BT40AD/B-EMH3/8-2.50	0.375	1.00	2.50
AH005B		BT40AD/B-EMH7/16-2.50	0.437	1.13	2.50
AH006B		BT40AD/B-EMH1/2-2.50	0.500	1.25	2.50
AH008B		BT40AD/B-EMH5/8-2.50	0.625	1.50	2.50
AH010B		BT40AD/B-EMH3/4-2.50	0.750	1.75	2.50
AH012B		BT40AD/B-EMH7/8-3.50	0.875	1.88	3.50
AH014B		BT40AD/B-EMH1"-3.75	1.000	2.00	3.75
AH017B		BT40AD/B-EMH1 1/4-3.75	1.250	2.50	3.75
AH021B		BT40AD/B-EMH1 1/2-4.25	1.500	2.50	4.25

EXTENDED

Unit : inch

EDP No.	TAPER No.	MODEL No.	d	D	L
AH104B	40	BT40AD/B-EMH3/8-4.00	0.375	1.00	4.00
AH106B		BT40AD/B-EMH1/2-4.00	0.500	1.25	4.00
AH108B		BT40AD/B-EMH5/8-4.00	0.625	1.50	4.00
AH110B		BT40AD/B-EMH3/4-4.00	0.750	1.75	4.00
AH114B		BT40AD/B-EMH1"-5.00	1.000	2.00	5.00
AH117B		BT40AD/B-EMH1 1/4-5.00	1.250	2.50	5.00
AH121B		BT40AD/B-EMH1 1/2-6.00	1.500	2.50	6.00

- * High balanced End Mill Holders are available on request.
- * Set screws for End Mill Holders on page 65.

END MILL HOLDER (COOLANT CHANNEL TYPE)

BT

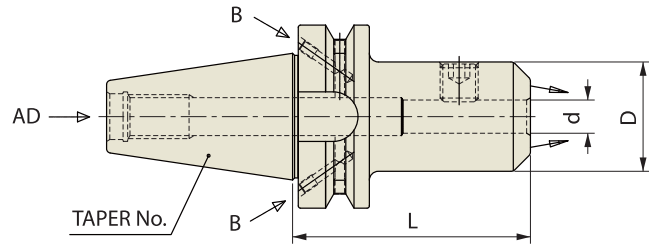

JIS B6339 -BT	Taper Accuracy AT3	G Value 6.3	RPM 15,000	Coolant System AD/B+C
------------------	---------------------------------	-----------------------	----------------------	------------------------------------

JIS B6339/MAS 403-BT

Unit : inch

EDP No.	TAPER No.	MODEL No.	d	D	L
AH002C	40	BT40AD/B-EMH1/4C-1.97	0.250	0.780	1.969
AH003C		BT40AD/B-EMH5/16C-1.97	0.313	0.880	1.969
AH004C		BT40AD/B-EMH3/8C-2.48	0.375	1.000	2.480
AH006C		BT40AD/B-EMH1/2C-2.48	0.500	1.250	2.480
AH008C		BT40AD/B-EMH5/8C-2.48	0.625	1.500	2.480
AH010C		BT40AD/B-EMH3/4C-2.48	0.750	1.750	2.480
AH012C		BT40AD/B-EMH1C-3.54	1.000	2.000	3.543
AH014C		BT40AD/B-EMH1 1/4C-3.94	1.250	2.500	3.937

- * High balanced End Mill Holders are available on request.
- * Set screws for End Mill Holders on page 65.

HIGH BALANCED END MILL HOLDER

BT

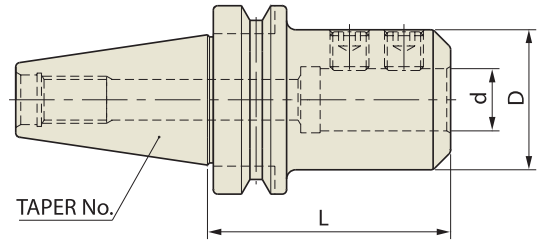

End Mill Holder
& Side Lock Arbor

JIS B6339/MAS 403-BT

JIS B6339 -BT	Taper Accuracy AT3	G Value 2.5	RPM 25,000	Coolant System AD
------------------	-----------------------	----------------	---------------	----------------------

STUB

Unit : inch

EDP No.	TAPER No.	MODEL No.	d	D	L
AH206B25	40	BT40-EMH1/2-1.25	0.500	1.25	1.25
AH208B25		BT40-EMH5/8-1.38	0.625	1.50	1.38
AH210B25		BT40-EMH3/4-1.44	0.750	1.75	1.44
AH214B25		BT40-EMH1"-2.50	1.000	2.00	2.50
AH217B25		BT40-EMH1 1/4-2.50	1.250	2.50	2.50

STANDARD

Unit : inch

EDP No.	TAPER No.	MODEL No.	d	D	L
AH000B25	40	BT40-EMH1/8-2.50	0.125	0.69	2.50
AH001B25		BT40-EMH3/16-2.50	0.187	0.69	2.50
AH002B25		BT40-EMH1/4-2.50	0.250	0.78	2.50
AH003B25		BT40-EMH5/16-2.50	0.312	0.88	2.50
AH004B25		BT40-EMH3/8-2.50	0.375	1.00	2.50
AH005B25		BT40-EMH7/16-2.50	0.437	1.13	2.50
AH006B25		BT40-EMH1/2-2.50	0.500	1.25	2.50
AH008B25		BT40-EMH5/8-2.50	0.625	1.50	2.50
AH010B25		BT40-EMH3/4-2.50	0.750	1.75	2.50
AH012B25		BT40-EMH7/8-3.50	0.875	1.88	3.50
AH014B25		BT40-EMH1"-3.75	1.000	2.00	3.75
AH017B25		BT40-EMH1 1/4-3.75	1.250	2.50	3.75
AH021B25		BT40-EMH1 1/2-4.25	1.500	2.50	4.25
AI002B25		50	BT50-EMH1/4-3.00	0.250	0.78
AI004B25	BT50-EMH3/8-3.00		0.375	1.00	3.00
AI006B25	BT50-EMH1/2-3.00		0.500	1.25	3.00
AI008B25	BT50-EMH5/8-3.00		0.625	1.50	3.00
AI010B25	BT50-EMH3/4-3.00		0.750	1.75	3.00
AI012B25	BT50-EMH7/8-4.00		0.875	1.88	4.00
AI014B25	BT50-EMH1"-4.25		1.000	2.00	4.25
AI017B25	BT50-EMH1 1/4-4.25		1.250	2.50	4.25
AI021B25	BT50-EMH1 1/2-4.25		1.500	2.50	4.25
AI029B25	BT50-EMH2"-5.00		2.000	3.75	5.00

* Set screws for End Mill Holders on page 65.

HIGH BALANCED END MILL HOLDER

BT

End Mill Holder
& Side Lock Arbor

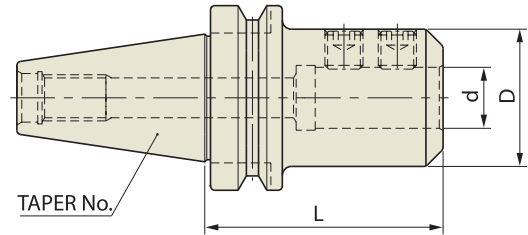

JIS B6339/MAS 403-BT

JIS B6339 -BT	Taper Accuracy AT3	G Value 2.5	RPM 25,000	Coolant System AD
------------------	---------------------------------	-----------------------	----------------------	--------------------------------

■ EXTENDED

Unit : inch

EDP No.	TAPER No.	MODEL No.	d	D	L
AH104B25	40	BT40-EMH3/8-4.00	0.375	1.00	4.00
AH106B25		BT40-EMH1/2-4.00	0.500	1.25	4.00
AH108B25		BT40-EMH5/8-4.00	0.625	1.50	4.00
AH110B25		BT40-EMH3/4-4.00	0.750	1.75	4.00
AH114B25		BT40-EMH1"-5.00	1.000	2.00	5.00
AH117B25		BT40-EMH1 1/4-5.00	1.250	2.50	5.00
AH121B25		BT40-EMH1 1/2-6.00	1.500	2.50	6.00
AI104B25		50	BT50-EMH3/8-6.00	0.375	1.00
AI106B25	BT50-EMH1/2-6.00		0.500	1.25	6.00
AI108B25	BT50-EMH5/8-6.00		0.625	1.50	6.00
AI110B25	BT50-EMH3/4-6.00		0.750	1.75	6.00
AI112B25	BT50-EMH7/8-6.00		0.875	1.88	6.00
AI114B25	BT50-EMH1"-6.00		1.000	2.00	6.00
AI117B25	BT50-EMH1 1/4-6.00		1.250	2.50	6.00
AI121B25	BT50-EMH1 1/2-6.00		1.500	2.50	6.00
AI129B25	BT50-EMH2"-6.00		2.000	3.75	6.00

* Set screws for End Mill Holders on page 65.

DUAL CONTACT SIDE LOCK ARBOR

CCT

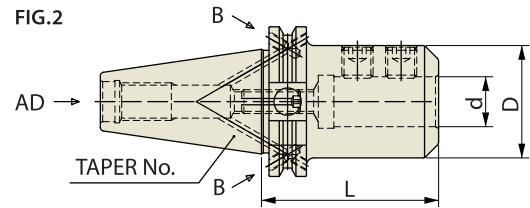
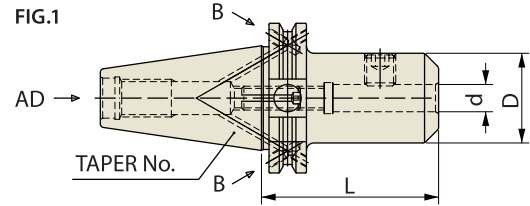

CCT	Taper Accuracy AT3	G Value 2.5	RPM 25,000	Coolant System AD/B
-----	------------------------------	-----------------------	----------------------	-------------------------------

CCT (CAT DUAL CONTACT)

Unit : inch

EDP No.	TAPER No.	MODEL No.	d	D	L	FIG.
AB020	40	CCT40AD/B-SLA1/4-2.36	0.250	0.780	2.362	1
AB022		CCT40AD/B-SLA5/16-2.36	0.313	0.880	2.362	1
AB024		CCT40AD/B-SLA3/8-2.36	0.375	1.000	2.362	1
AB026		CCT40AD/B-SLA1/2-2.36	0.500	1.250	2.362	1
AB028		CCT40AD/B-SLA5/8-3.54	0.625	1.500	3.543	1
AB030		CCT40AD/B-SLA3/4-3.54	0.750	1.750	3.543	1
AB032		CCT40AD/B-SLA1"-3.54	1.000	2.000	3.543	2
AB034		CCT40AD/B-SLA1 1/4-3.54	1.250	2.500	3.543	2
AC020	50	CCT50AD/B-SLA1/4-3.54	0.250	0.780	3.543	1
AC022		CCT50AD/B-SLA5/16-3.54	0.313	0.880	3.543	1
AC024		CCT50AD/B-SLA3/8-3.54	0.375	1.000	3.543	1
AC026		CCT50AD/B-SLA1/2-3.54	0.500	1.250	3.543	1
AC028		CCT50AD/B-SLA5/8-4.13	0.625	1.500	4.134	1
AC030		CCT50AD/B-SLA3/4-4.13	0.750	1.750	4.134	1
AC032		CCT50AD/B-SLA1"-4.13	1.000	2.000	4.134	2
AC034		CCT50AD/B-SLA1 1/4-4.13	1.250	2.500	4.134	2

* Set screws for End Mill Holders on page 65.

DUAL CONTACT SIDE LOCK ARBOR

CBT

End Mill Holder
& Side Lock Arbor



FIG.1

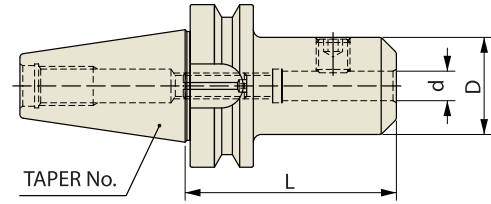
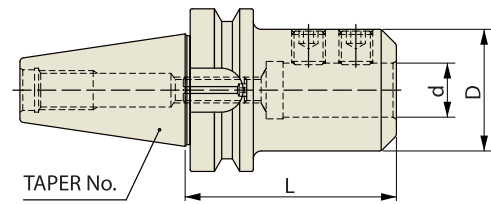

FIG.2



CBT	Taper Accuracy AT3	G Value 2.5	RPM 25,000	Coolant System AD
-----	------------------------------	-----------------------	----------------------	-----------------------------

CBT (BT DUAL CONTACT)

Unit : inch

EDP No.	TAPER No.	MODEL No.	d	D	L	FIG.
AD020	30	CBT30-SLA1/4-2.36	0.250	0.780	2.362	1
AD022		CBT30-SLA5/16-2.36	0.313	0.880	2.362	1
AD024		CBT30-SLA3/8-2.36	0.375	1.000	2.362	1
AD026		CBT30-SLA1/2-2.36	0.500	1.250	2.362	1
AD028		CBT30-SLA5/8-2.95	0.625	1.500	2.953	1
AD030		CBT30-SLA3/4-2.95	0.750	1.750	2.953	2
AD032		CBT30-SLA1"-2.95	1.000	2.000	2.953	2
AE020		40	CBT40-SLA1/4-2.36	0.250	0.780	2.362
AE022	CBT40-SLA5/16-2.36		0.313	0.880	2.362	1
AE024	CBT40-SLA3/8-2.36		0.375	1.000	2.362	1
AE026	CBT40-SLA1/2-2.36		0.500	1.250	2.362	1
AE028	CBT40-SLA5/8-3.54		0.625	1.500	3.543	1
AE030	CBT40-SLA3/4-3.54		0.750	1.750	3.543	1
AE032	CBT40-SLA1"-3.54		1.000	2.000	3.543	2
AE034	CBT40-SLA1 1/4-3.54		1.250	2.500	3.543	2

* Set screws for End Mill Holders on page 65.

DUAL CONTACT END MILL HOLDER (COOLANT CHANNEL TYPE)

HSK

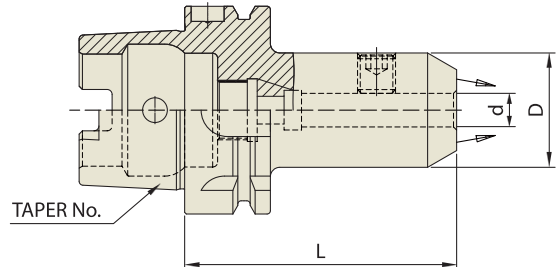

DIN 69893
- HSK

Taper Accuracy
-

G Value
2.5

RPM
25,000

Coolant System
AD+C

DIN 69893/ISO 12164-1-HSK FORM A

Unit : inch

EDP No.	TAPER No.	MODEL No.	d	D	L	
AQ020C	63A	HSK63A-EMH1/4C-2.56	0.250	0.780	2.559	
AQ022C		HSK63A-EMH5/16C-2.56	0.313	0.880	2.559	
AQ024C		HSK63A-EMH3/8C-2.56	0.375	1.000	2.559	
AQ026C		HSK63A-EMH1/2C-3.15	0.500	1.250	3.150	
AQ028C		HSK63A-EMH5/8C-3.15	0.625	1.500	3.150	
AQ030C		HSK63A-EMH3/4C-3.15	0.750	1.750	3.150	
AQ032C		HSK63A-EMH1C-4.33	1.000	2.000	4.331	
AQ034C		HSK63A-EMH1 1/4C-4.33	1.250	2.500	4.331	
AR020C		100A	HSK100A-EMH1/4C-3.15	0.250	0.780	3.150
AR022C			HSK100A-EMH5/16C-3.15	0.313	0.880	3.150
AR024C	HSK100A-EMH3/8C-3.15		0.375	1.000	3.150	
AR026C	HSK100A-EMH1/2C-3.15		0.500	1.250	3.150	
AR028C	HSK100A-EMH5/8C-3.94		0.625	1.500	3.937	
AR030C	HSK100A-EMH3/4C-3.94		0.750	1.750	3.937	
AR032C	HSK100A-EMH1C-3.94		1.000	2.000	3.937	
AR034C	HSK100A-EMH1 1/4C-3.94		1.250	2.500	3.937	

END MILL HOLDER SCREWS

HEXAGON SOCKET SET SCREW (FLAT TYPE)

EDP No.	SCREW	END MILL Dia.
ZZ000	UNC#8-32	1/8
ZZ001	UNF#10-32	3/16
ZZ002	UNF1/4-28	1/4
ZZ003	UNF5/16-24	5/16
ZZ004	UNF3/8-24	3/8
ZZ005	UNF3/8-24	7/16
ZZ006	UNF7/16-20	1/2
ZZ007	UNF1/2-20	5/8
ZZ008	UNF5/8-18	3/4
ZZ009	UNF5/8-18	7/8
ZZ010	UNF3/4-16	1"
ZZ011	UNF3/4-16	1 1/4
ZZ012	UNF3/4-16	1 1/2
ZZ013	UN1"-14	2"

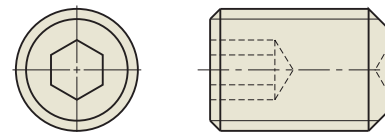

Rotary Tooling



**THE WORLD LEADER IN
THE TOOL HOLDER INDUSTRY**

-
- HYDRAULIC CHUCK
 - SHRINK FIT HOLDER
 - END MILL HOLDER & SIDE LOCK ARBOR
 - ER COLLET CHUCK
 - SK SLIM CHUCK
 - TG COLLET CHUCK
 - POWER MILLING CHUCK
 - MORSE TAPER ADAPTER
 - TAPPING CHUCK
 - SHELL MILL ARBOR
 - NC DRILL CHUCK
 - JACOBS TAPER ARBOR
 - STUB ARBOR
 - SLITTING SAW ARBOR
 - PULL STUD & TOOL CLAMP
-





ROTARY TOOLING

ER COLLET CHUCK



ER COLLET CHUCK

CAT : ASME B5.50-2009

BT : JIS B6339/MAS 403

DUAL CONTACT ER COLLET CHUCK

HSK : DIN 69893/ISO 12164-1

SHORT & TENSION ER COLLET CHUCK

SHORT

TENSION (For TAPPING)

NC ER COLLET CHUCK

NC (For CNC LATHE)

ACCESSORY & PART

- ER NUT / ER WRENCH / ER STOP SCREW / ER COLLET / TAP ER COLLET

ER COLLET CHUCK

CAT

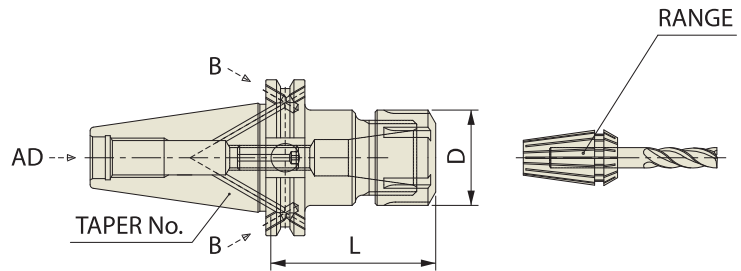

ER Collet Chuck

ASME B5.50 - CAT	Taper Accuracy AT3	G Value 6.3	RPM 15,000	Coolant System AD/B
------------------	------------------------------	-----------------------	----------------------	-------------------------------

ASME B5.50-2009-CAT

■ STUB

Unit : inch

EDP No.	TAPER No.	MODEL No.	CLAMPING RANGE	D	L	COLLET SERIES
BK232B	40	CAT40AD/B-ER20-2.55	0.039 - 0.511	1.26	2.55	ER20
BK233B		CAT40AD/B-ER25-2.50	0.039 - 0.629	1.65	2.50	ER25
BK234B		CAT40AD/B-ER32-2.70	0.078 - 0.787	1.88	2.70	ER32

■ STANDARD

Unit : inch

EDP No.	TAPER No.	MODEL No.	CLAMPING RANGE	D	L	COLLET SERIES
BK030B	40	CAT40AD/B-ER11-3.00	0.019 - 0.275	0.75	3.00	ER11
BK031B		CAT40AD/B-ER16-3.00	0.019 - 0.393	1.10	3.00	ER16
BK032B		CAT40AD/B-ER20-4.00	0.039 - 0.511	1.33	4.00	ER20
BK133B		CAT40AD/B-ER25-4.00	0.039 - 0.629	1.65	4.00	ER25
BK134B		CAT40AD/B-ER32-4.00	0.078 - 0.787	1.96	4.00	ER32
BK136B		CAT40AD/B-ER40-4.00	0.118 - 1.024	2.48	4.00	ER40
BL031B	50	CAT50AD/B-ER16-4.00	0.031 - 0.406	1.10	4.00	ER16
BL032B		CAT50AD/B-ER20-4.00	0.039 - 0.511	1.33	4.00	ER20
BL033B		CAT50AD/B-ER25-4.00	0.039 - 0.629	1.65	4.00	ER25
BL034B		CAT50AD/B-ER32-4.00	0.078 - 0.787	1.96	4.00	ER32
BL036B		CAT50AD/B-ER40-4.00	0.118 - 1.024	2.48	4.00	ER40

■ EXTENDED

Unit : inch

EDP No.	TAPER No.	MODEL No.	CLAMPING RANGE	D	L	COLLET SERIES
BK331B	40	CAT40AD/B-ER16-6.00	0.019 - 0.393	1.10	6.00	ER16
BK332B		CAT40AD/B-ER20-6.00	0.039 - 0.511	1.33	6.00	ER20
BK333B		CAT40AD/B-ER25-6.00	0.039 - 0.629	1.65	6.00	ER25
BK334B		CAT40AD/B-ER32-6.00	0.078 - 0.787	1.96	6.00	ER32
BL331B	50	CAT50AD/B-ER16-6.00	0.031 - 0.406	1.10	6.00	ER16
BL332B		CAT50AD/B-ER20-6.00	0.039 - 0.511	1.33	6.00	ER20
BL333B		CAT50AD/B-ER25-6.00	0.039 - 0.629	1.65	6.00	ER25
BL334B		CAT50AD/B-ER32-6.00	0.078 - 0.787	1.96	6.00	ER32

■ EXTRA EXTENDED

Unit : inch

EDP No.	TAPER No.	MODEL No.	CLAMPING RANGE	D	L	COLLET SERIES
BK432B	40	CAT40AD/B-ER20-8.00	0.039 - 0.511	1.33	8.00	ER20

- * High balanced ER Collet Chucks are available on request.
- * Supplied without wrench.
- * ER collets on page 77~85 and Nut / Wrench / Stop Screw on page 76.

HIGH BALANCED ER COLLET CHUCK

CAT

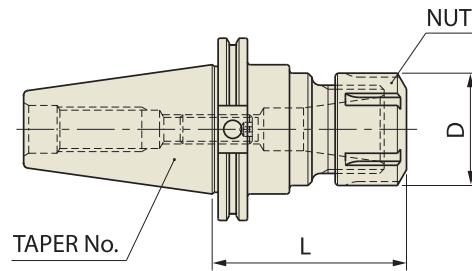

ER Collet Chuck

ASME B5.50-2009-CAT

ASME B5.50 - CAT	Taper Accuracy AT3	G Value 2.5	RPM 25,000	Coolant System AD
---------------------	------------------------------	-----------------------	----------------------	-----------------------------

■ STUB

Unit : inch

EDP No.	TAPER No.	MODEL No.	CLAMPING RANGE	D	L	COLLET SERIES
BK232B25	40	CAT40-ER20-2.55	0.039 - 0.511	1.339	2.55	ER20
BK233B25		CAT40-ER25-2.50	0.039 - 0.629	1.654	2.50	ER25
BK234B25		CAT40-ER32-2.70	0.078 - 0.787	1.969	2.70	ER32

■ STANDARD

Unit : inch

EDP No.	TAPER No.	MODEL No.	CLAMPING RANGE	D	L	COLLET SERIES
BK030B25	40	CAT40-ER11-3.00	0.019 - 0.275	0.748	3.00	ER11
BK031B25		CAT40-ER16-2.88	0.019 - 0.393	1.102	2.88	ER16
BK032B25		CAT40-ER20-4.00	0.039 - 0.511	1.339	4.00	ER20
BK133B25		CAT40-ER25-4.00	0.039 - 0.629	1.654	4.00	ER25
BK134B25		CAT40-ER32-4.00	0.078 - 0.787	1.969	4.00	ER32
BL031B25	50	CAT50-ER16-4.00	1/32 - 13/32	1.102	4.88	ER16
BL032B25		CAT50-ER20-4.00	0.039 - 0.511	1.339	4.00	ER20
BL033B25		CAT50-ER25-4.00	0.039 - 0.629	1.654	4.00	ER25
BL034B25		CAT50-ER32-4.00	0.078 - 0.787	1.969	4.00	ER32

■ EXTENDED

Unit : inch

EDP No.	TAPER No.	MODEL No.	CLAMPING RANGE	D	L	COLLET SERIES
BK331B25	40	CAT40-ER16-4.88	0.019 - 0.393	1.102	4.88	ER16
BK332B25		CAT40-ER20-6.00	0.039 - 0.511	1.339	6.00	ER20
BK333B25		CAT40-ER25-6.00	0.039 - 0.629	1.654	6.00	ER25
BK334B25		CAT40-ER32-6.00	0.078 - 0.787	1.969	6.00	ER32
BL331B25	50	CAT50-ER16-6.88	1/32 - 13/32	1.102	6.88	ER16
BL332B25		CAT50-ER20-6.00	0.039 - 0.511	1.339	6.00	ER20
BL333B25		CAT50-ER25-6.00	0.039 - 0.629	1.654	6.00	ER25
BL334B25		CAT50-ER32-6.00	0.078 - 0.787	1.969	6.00	ER32

■ EXTRA EXTENDED

Unit : inch

EDP No.	TAPER No.	MODEL No.	CLAMPING RANGE	D	L	COLLET SERIES
BK432B25	40	CAT40-ER20-8.00	0.039 - 0.511	1.339	8.00	ER20

* Supplied without wrench.

* ER collets on page 77~85 and Nut / Wrench / Stop Screw on page 76.

ER COLLET CHUCK

BT

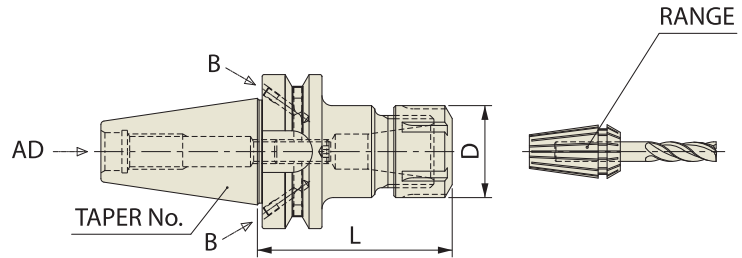

ER Collet Chuck

JIS B6339/MAS 403-BT

JIS B6339 -BT	Taper Accuracy AT3	G Value 6.3	RPM 15,000	Coolant System AD/B
------------------	------------------------------	-----------------------	----------------------	-------------------------------

■ STUB

Unit : inch

EDP No.	TAPER No.	MODEL No.	CLAMPING RANGE	D	L	COLLET SERIES
BH232B	40	BT40AD/B-ER20-2.20	0.039 - 0.511	1.33	2.20	ER20
BH233B		BT40AD/B-ER25-2.50	0.039 - 0.629	1.65	2.50	ER25
BH234B		BT40AD/B-ER32-2.40	0.078 - 0.787	1.96	2.40	ER32

■ STANDARD

Unit : inch

EDP No.	TAPER No.	MODEL No.	CLAMPING RANGE	D	L	COLLET SERIES
BH030B	40	BT40AD/B-ER11-3.00	0.019 - 0.275	0.75	3.00	ER11
BH031B		BT40AD/B-ER16-3.00	0.019 - 0.393	1.10	3.00	ER16
BH032B		BT40AD/B-ER20-4.00	0.039 - 0.511	1.33	4.00	ER20
BH133B		BT40AD/B-ER25-4.00	0.039 - 0.629	1.65	4.00	ER25
BH134B		BT40AD/B-ER32-4.00	0.078 - 0.787	1.96	4.00	ER32
BH136B		BT40AD/B-ER40-4.00	0.118 - 1.024	2.48	4.00	ER40

■ EXTENDED

Unit : inch

EDP No.	TAPER No.	MODEL No.	CLAMPING RANGE	D	L	COLLET SERIES
BH331B	40	BT40AD/B-ER16-6.00	0.019 - 0.393	1.10	6.00	ER16
BH332B		BT40AD/B-ER20-6.00	0.039 - 0.511	1.33	6.00	ER20
BH333B		BT40AD/B-ER25-6.00	0.039 - 0.629	1.65	6.00	ER25
BH334B		BT40AD/B-ER32-6.00	0.078 - 0.787	1.96	6.00	ER32

■ EXTRA EXTENDED

Unit : inch

EDP No.	TAPER No.	MODEL No.	CLAMPING RANGE	D	L	COLLET SERIES
BH432B	40	BT40AD/B-ER20-8.00	0.039 - 0.511	1.33	8.00	ER20

- * High balanced ER Collet Chucks are available on request.
- * Supplied without wrench.
- * ER collets on page 77~85 and Nut / Wrench / Stop Screw on page 76.

ER COLLET CHUCK

BT

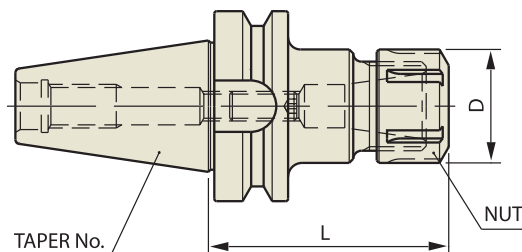

ER Collet
Chuck

JIS B6339/MAS 403-BT

JIS B6339 -BT	Taper Accuracy AT3	G Value 6.3	RPM 15,000	Coolant System AD
------------------	--------------------------	----------------	---------------	-------------------------

■ STANDARD

Unit : inch

EDP No.	TAPER No.	MODEL No.	CLAMPING RANGE	D	L	COLLET SERIES
BI031	50	BT50-ER16-4.88	0.019 - 0.393	1.102	4.88	ER16
BI032		BT50-ER20-2.63	0.039 - 0.511	1.339	2.63	ER20
BI033		BT50-ER25-2.63	0.039 - 0.629	1.654	2.63	ER25
BI034		BT50-ER32-4.00	0.078 - 0.787	1.969	4.00	ER32

■ EXTENDED

Unit : inch

EDP No.	TAPER No.	MODEL No.	CLAMPING RANGE	D	L	COLLET SERIES
BI331	50	BT50-ER16-6.00	0.019 - 0.393	1.102	6.00	ER16
BI332		BT50-ER20-6.00	0.039 - 0.511	1.339	6.00	ER20
BI333		BT50-ER25-6.00	0.039 - 0.629	1.654	6.00	ER25
BI334		BT50-ER32-6.00	0.078 - 0.787	1.969	6.00	ER32

* High balanced ER Collet Chucks are on page 72.

* Supplied without wrench.

* ER collets on page 77~85 and Nut / Wrench / Stop Screw on page 76.

HIGH BALANCED ER COLLET CHUCK

BT

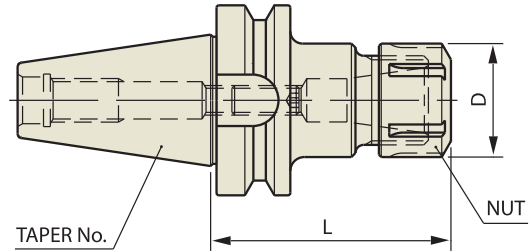

ER Collet
Chuck

JIS B6339/MAS 403-BT

JIS B6339 -BT	Taper Accuracy AT3	G Value 2.5	RPM 25,000	Coolant System AD
------------------	------------------------------	-----------------------	----------------------	-----------------------------

■ STUB

Unit : inch

EDP No.	TAPER No.	MODEL No.	CLAMPING RANGE	D	L	COLLET SERIES
BH232B25	40	BT40-ER20-2.20	0.039 - 0.511	1.339	2.20	ER20
BH233B25		BT40-ER25-2.50	0.039 - 0.629	1.654	2.50	ER25
BH234B25		BT40-ER32-2.40	0.078 - 0.787	1.969	2.40	ER32

■ STANDARD

Unit : inch

EDP No.	TAPER No.	MODEL No.	CLAMPING RANGE	D	L	COLLET SERIES
BH030B25	40	BT40-ER11-3.00	0.019 - 0.275	0.748	3.00	ER11
BH031B25		BT40-ER16-2.88	0.019 - 0.393	1.102	2.88	ER16
BH032B25		BT40-ER20-4.00	0.039 - 0.511	1.339	4.00	ER20
BH133B25		BT40-ER25-4.00	0.039 - 0.629	1.654	4.00	ER25
BH134B25		BT40-ER32-4.00	0.078 - 0.787	1.969	4.00	ER32
BI031B25	50	BT50-ER16-4.88	1/32 - 13/32	1.102	4.88	ER16
BI032B25		BT50-ER20-2.63	0.039 - 0.511	1.339	2.63	ER20
BI033B25		BT50-ER25-2.63	0.039 - 0.629	1.654	2.63	ER25
BI034B25		BT50-ER32-4.00	0.078 - 0.787	1.969	4.00	ER32

■ EXTENDED

Unit : inch

EDP No.	TAPER No.	MODEL No.	CLAMPING RANGE	D	L	COLLET SERIES
BH331B25	40	BT40-ER16-4.88	0.019 - 0.393	1.102	4.88	ER16
BH332B25		BT40-ER20-6.00	0.039 - 0.511	1.339	6.00	ER20
BH333B25		BT40-ER25-6.00	0.039 - 0.629	1.654	6.00	ER25
BH334B25		BT40-ER32-6.00	0.078 - 0.787	1.969	6.00	ER32
BI331B25	50	BT50-ER16-6.00	1/32 - 13/32	1.102	6.00	ER16
BI332B25		BT50-ER20-6.00	0.039 - 0.511	1.339	6.00	ER20
BI333B25		BT50-ER25-6.00	0.039 - 0.629	1.654	6.00	ER25
BI334B25		BT50-ER32-6.00	0.078 - 0.787	1.969	6.00	ER32

■ EXTRA EXTENDED

Unit : inch

EDP No.	TAPER No.	MODEL No.	CLAMPING RANGE	D	L	COLLET SERIES
BH432B25	40	BT40-ER20-8.00	0.039 - 0.511	1.339	8.00	ER20

* Supplied without wrench.

* ER collets on page 77~85 and Nut / Wrench / Stop Screw on page 76.

DUAL CONTACT ER COLLET CHUCK

HSK

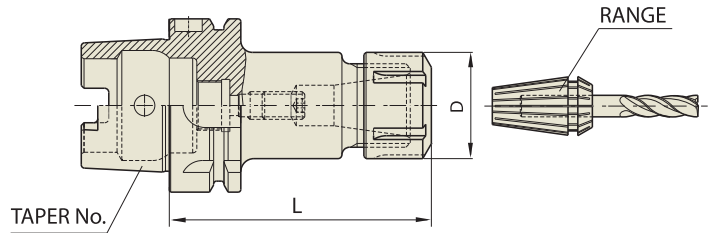

ER Collet
Chuck

DIN 69893 - HSK	Taper Accuracy -	G Value 2.5	RPM 25,000	Coolant System AD
--------------------	------------------------	----------------	---------------	-------------------------

DIN 69893/ISO 12164-1-HSK FORM A

Unit : inch

EDP No.	TAPER No.	MODEL No.	CLAMPING RANGE	D	L	COLLET SERIES
BQ010	63A	HSK63A-ER16-3.94	0.019 - 0.393	1.10	3.94	ER16
BQ012		HSK63A-ER20-3.94	0.039 - 0.511	1.33	3.94	ER20
BQ014		HSK63A-ER25-3.94	0.039 - 0.629	1.65	3.94	ER25
BQ016		HSK63A-ER32-3.94	0.078 - 0.787	1.96	3.94	ER32
BQ018		HSK63A-ER40-4.72	0.118 - 1.18	2.48	4.72	ER40
BR010	100A	HSK100A-ER16-3.94	0.019 - 0.393	1.10	3.94	ER16
BR012		HSK100A-ER20-3.94	0.039 - 0.511	1.33	3.94	ER20
BR014		HSK100A-ER25-3.94	0.039 - 0.629	1.65	3.94	ER25
BR016		HSK100A-ER32-3.94	0.078 - 0.787	1.96	3.94	ER32
BR018		HSK100A-ER40-4.72	0.118 - 1.18	2.48	4.72	ER40

* Supplied without wrench.

* ER collets on page 77~85 and Nut / Wrench / Stop Screw on page 76.

ER COLLET CHUCK (SHORT)

CAT/BT

ER Collet
Chuck

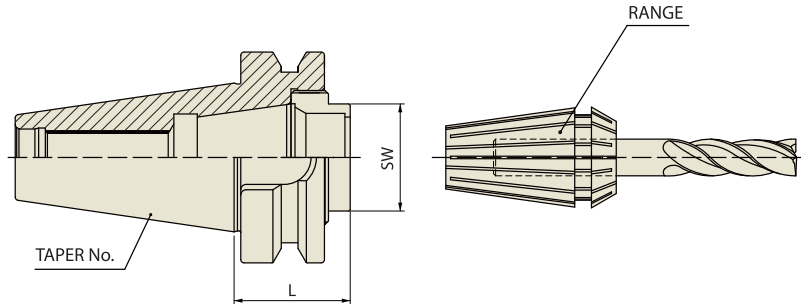

ASME B5.50-2009-CAT

Unit : inch

EDP No.	TAPER No.	MODEL No.	L	ER WRENCH
BK020SHT	40	CAT40-ER32-SHORT	1.063	32 (for Hex. Nut)
BL020SHT	50	CAT50-ER32-SHORT	1.063	32 (for Hex. Nut)

JIS B6339/MAS 403-BT

Unit : inch

EDP No.	TAPER No.	MODEL No.	L	ER WRENCH
BH020SHT	40	BT40-ER32-SHORT	1.378	32 (for Hex. Nut)

TENSION ER COLLET CHUCK (For TAPPING)

K

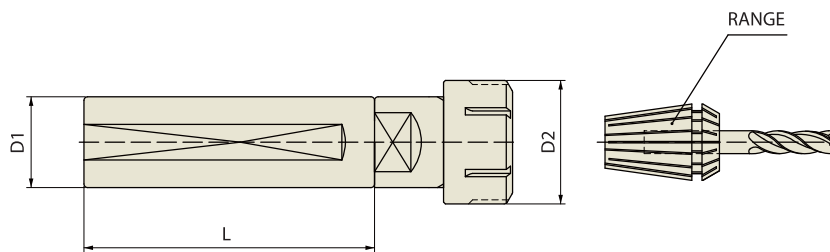

STRAIGHT-K

Unit : inch

EDP No.	TAPER No.	MODEL No.	D1	D2	L
BS110	K	K1-ERT16-2.76	1.000	1.102	2.756
BS111		K1-ERT20-3.15	1.000	1.339	3.150
BS112		K1 1/4-ERT16-2.76	1.250	1.102	2.756
BS113		K1 1/4-ERT20-3.15	1.250	1.339	3.150
BS114		K1 1/4-ERT25-3.15	1.250	1.654	3.150
BS115		K1 1/4-ERT32-3.15	1.250	1.969	3.150

* Supplied without wrench.

* ER collets on page 77~85 and Nut / Wrench / Stop Screw on page 76.

NC ER COLLET CHUCK (For CNC LATHE)

NC

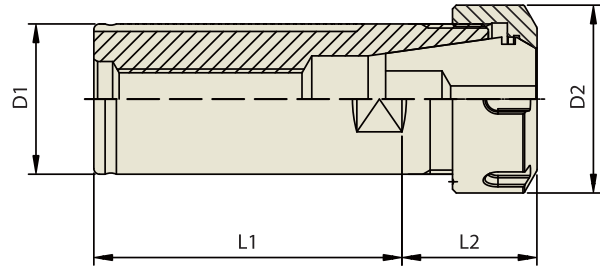

ER Collet
Chuck

NC

Unit : inch

EDP No.	TAPER No.	MODEL No.	D1	D2	L1	L2
BN110	NC	NC1-ER11	1.000	0.748	2.559	1.260
BN111		NC1-ER16	1.000	1.102	2.559	1.260
BN112		NC1-ER20	1.000	1.339	2.559	1.260
BN113		NC1-ER25	1.000	1.654	2.559	1.260
BN114		NC1 1/4-ER20	1.250	1.339	2.756	1.260
BN115		NC1 1/4-ER25	1.250	1.654	2.756	1.496
BN116		NC1 1/4-ER32	1.250	1.969	2.756	1.496
BN117		NC1 1/4-ER40	1.250	2.480	2.953	1.496
BN118		NC1 1/2-ER25	1.500	1.654	2.953	2.087
BN119		NC1 1/2-ER32	1.500	1.969	2.953	2.087
BN120		NC1 1/2-ER40	1.500	2.480	2.953	2.087

* Supplied without wrench.

* ER collets on page 77~85 and Nut / Wrench / Stop Screw on page 76.

ER NUT

FIG.1

EDP No.	SERIES	TYPE
ZZ061	ER11-NUT	FIG.1
ZZ063	ER16-NUT	FIG.1
ZZ066	ER20-NUT	FIG.1

FIG.2

EDP No.	SERIES	TYPE
ZZ069	ER25-NUT	FIG.2
ZZ072	ER32-NUT	FIG.2
ZZ077	ER40-NUT	FIG.2

FIG.1



FIG.2

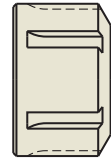

ER WRENCH

FIG.1

EDP No.	SERIES	TYPE
ZZ062	ER11	FIG.1
ZZ064	ER16	FIG.1
ZZ067	ER20	FIG.1

FIG.2

EDP No.	SERIES	TYPE
ZZ070	ER25	FIG.2
ZZ073	ER32	FIG.2
ZZ076	ER40	FIG.2



FIG.1



FIG.2

* Design and shape could be changed without prior notice.

ER STOP SCREW

FIG.1

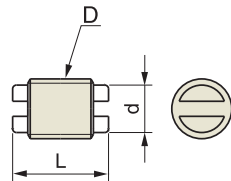

FIG.2

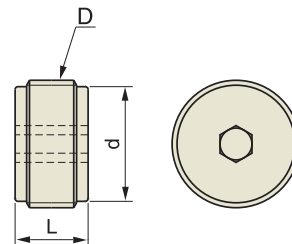

FIG.1

EDP No.	SERIES	L	d	D	TYPE
ZZ060	ER11	0.50	0.25	UN5/16-18	FIG.1

FIG.2

EDP No.	SERIES	L	d	D	TYPE
ZZ065	ER16	0.50	0.35	UN7/16-16	FIG.2
ZZ068	ER20	0.50	0.48	UN9/16-16	FIG.2
ZZ071	ER25	0.50	0.60	UN11/16-16	FIG.2
ZZ074	ER32	0.50	0.79	UN7/8-16	FIG.2

ER COLLET (INCH TYPE)

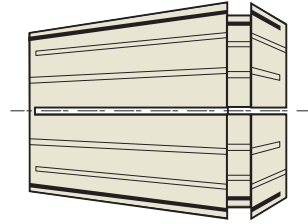

ER Collet
Chuck

Unit : inch

ER 11		ER 16		ER 20		ER 25		ER 32		ER 40	
EDP No.	CLAMPING CAPACITY	EDP No.	CLAMPING CAPACITY	EDP No.	CLAMPING CAPACITY	EDP No.	CLAMPING CAPACITY	EDP No.	CLAMPING CAPACITY	EDP No.	CLAMPING CAPACITY
110116	1/16	160116	1/16	200116	1/16	250116	1/16	320332	3/32	400108	1/8
110332	3/32	160332	3/32	200332	3/32	250332	3/32	320108	1/8	400532	5/32
110108	1/8	160108	1/8	200108	1/8	250108	1/8	320532	5/32	400316	3/16
110532	5/32	160532	5/32	200532	5/32	250532	5/32	320316	3/16	400732	7/32
110316	3/16	160316	3/16	200316	3/16	250316	3/16	320732	7/32	400104	1/4
110732	7/32	160732	7/32	200732	7/32	250732	7/32	320104	1/4	400932	9/32
110104	1/4	160104	1/4	200104	1/4	250104	1/4	320932	9/32	400516	5/16
		160932	9/32	200932	9/32	250932	9/32	320516	5/16	401132	11/32
		160516	5/16	200516	5/16	250516	5/16	321132	11/32	400308	3/8
		161132	11/32	201132	11/32	251132	11/32	320308	3/8	401332	13/32
		160308	3/8	200308	3/8	250308	3/8	321332	13/32	400716	7/16
		161332	13/32	201332	13/32	251332	13/32	320716	7/16	401532	15/32
				200716	7/16	250716	7/16	321532	15/32	400102	1/2
				201532	15/32	251532	15/32	320102	1/2	401732	17/32
				200102	1/2	250102	1/2	321732	17/32	400916	9/16
						251732	17/32	320916	9/16	401932	19/32
						250916	9/16	321932	19/32	400508	5/8
						251932	19/32	320508	5/8	402132	21/32
						250508	5/8	322132	21/32	401116	11/16
								321116	11/16	402332	23/32
								322332	23/32	400304	3/4
								320304	3/4	402532	25/32
										401316	13/16
										402732	27/32
										400708	7/8
										402932	29/32
										401516	15/16
										403132	31/32
										401000	1
ER11S07	STANDARD SET	ER16S12	STANDARD SET	ER20S15	STANDARD SET	ER25S19	STANDARD SET	ER32S22	STANDARD SET	ER40S29	STANDARD SET
Ø1/16" to 1/4"		Ø1/16" to 13/32"		Ø1/16" to 1/2"		Ø1/16" to 5/8"		Ø3/32" to 3/4"		Ø1/8" to 1"	
7pcs		12pcs		15pcs		19pcs		22pcs		29pcs	

ER COLLET (METRIC TYPE)

ER Collet
Chuck



Unit : mm

ER 8		ER 11		ER 16		ER 20	
EDP No.	CLAMPING RANGE	EDP No.	CLAMPING RANGE	EDP No.	CLAMPING RANGE	EDP No.	CLAMPING RANGE
208010	1.0 - 0.5	211010	1.0 - 0.5	216010	1.0 - 0.5	220010	1.0 - 0.5
208015	1.5 - 1.0	211015	1.5 - 1.0	216015	1.5 - 1.0	220015	1.5 - 1.0
208020	2.0 - 1.5	211020	2.0 - 1.5	216020	2.0 - 1.0	220020	2.0 - 1.0
208025	2.5 - 2.0	211025	2.5 - 2.0	216025	2.5 - 2.0	220025	2.5 - 2.0
208030	3.0 - 2.5	211030	3.0 - 2.5	216030	3.0 - 2.0	220030	3.0 - 2.0
208035	3.5 - 3.0	211035	3.5 - 3.0	216040	4.0 - 3.0	220040	4.0 - 3.0
208040	4.0 - 3.5	211040	4.0 - 3.5	216050	5.0 - 4.0	220050	5.0 - 4.0
208045	4.5 - 4.0	211045	4.5 - 4.0	216060	6.0 - 5.0	220060	6.0 - 5.0
208050	5.0 - 4.5	211050	5.0 - 4.5	216070	7.0 - 6.0	220070	7.0 - 6.0
		211055	5.5 - 5.0	216080	8.0 - 7.0	220080	8.0 - 7.0
		211060	6.0 - 5.5	216090	9.0 - 8.0	220090	9.0 - 8.0
		211065	6.5 - 6.0	216100	10.0 - 9.0	220100	10.0 - 9.0
		211070	7.0 - 6.5			220110	11.0 - 10.0
						220120	12.0 - 11.0
						220130	13.0 - 12.0
208000	STANDARD SET	211000	STANDARD SET	216000	STANDARD SET	220000	STANDARD SET
Ø1.0 - 5.0mm		Ø1.0 - 7.0mm		Ø1.0 - 10.0mm		Ø2.0 - 13.0mm	
9pcs		13pcs		10pcs		12pcs	
108110	WOODEN TRAY ZWT 8	011110	WOODEN TRAY ZWT 11	016110	WOODEN TRAY ZWT 16	020110	WOODEN TRAY ZWT 20

SEALED ER COLLET (INCH TYPE)

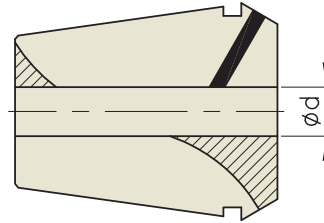

Unit : inch

ER 11S		ER 16S		ER 20S		ER 25S		ER 32S		ER 40S	
EDP No.	CLAMPING CAPACITY	EDP No.	CLAMPING CAPACITY	EDP No.	CLAMPING CAPACITY	EDP No.	CLAMPING CAPACITY	EDP No.	CLAMPING CAPACITY	EDP No.	CLAMPING CAPACITY
110108S	1/8	160108S	1/8	200108S	1/8	250108S	1/8	320108S	1/8	400108S	1/8
110532S	5/32	160532S	5/32	200532S	5/32	250532S	5/32	320532S	5/32	400532S	5/32
110316S	3/16	160316S	3/16	200316S	3/16	250316S	3/16	320316S	3/16	400316S	3/16
110732S	7/32	160732S	7/32	200732S	7/32	250732S	7/32	320732S	7/32	400732S	7/32
110104S	1/4	160104S	1/4	200104S	1/4	250104S	1/4	320104S	1/4	400104S	1/4
		160932S	9/32	200932S	9/32	250932S	9/32	320932S	9/32	400932S	9/32
		160516S	5/16	200516S	5/16	250516S	5/16	320516S	5/16	400516S	5/16
		161132S	11/32	201132S	11/32	251132S	11/32	321132S	11/32	401132S	11/32
		160308S	3/8	200308S	3/8	250308S	3/8	320308S	3/8	400308S	3/8
		161332S	13/32	201332S	13/32	251332S	13/32	321332S	13/32	401332S	13/32
				200716S	7/16	250716S	7/16	320716S	7/16	400716S	7/16
				201532S	15/32	251532S	15/32	321532S	15/32	401532S	15/32
				200102S	1/2	250102S	1/2	320102S	1/2	400102S	1/2
						251732S	17/32	321732S	17/32	401732S	17/32
						250916S	9/16	320916S	9/16	400916S	9/16
						251932S	19/32	321932S	19/32	401932S	19/32
						250508S	5/8	320508S	5/8	400508S	5/8
								322132S	21/32	402132S	21/32
								321116S	11/16	401116S	11/16
								322332S	23/32	402332S	23/32
								320304S	3/4	400304S	3/4
										402532S	25/32
										401316S	13/16
										402732S	27/32
										400708S	7/8
										402932S	29/32
										401516S	15/16
										403132S	31/32
										401000S	1
ER11S05S	STANDARD SET	ER16S10S	STANDARD SET	ER20S13S	STANDARD SET	ER25S17S	STANDARD SET	ER32S21S	STANDARD SET	ER40S29S	STANDARD SET
Ø1/8" to 1/4"		Ø1/8" to 13/32"		Ø1/8" to 1/2"		Ø1/8" to 5/8"		Ø1/8" to 3/4"		Ø1/8" to 1"	
5pcs		10pcs		13pcs		17pcs		21pcs		29pcs	

* Metric sealed ER collets are available on request.

TAP ER COLLET (INCH TYPE : ANSI)

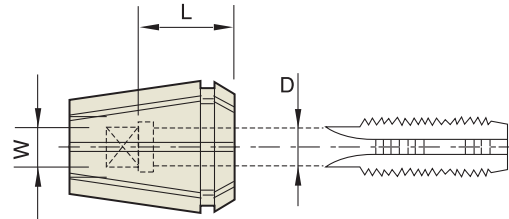

ER Collet
Chuck

Below standard Tap ER Collet conforms to **ANSI** (For STANDARD TAPS)

Unit : inch

RD 11TC						RD 16TC						RD 20TC					
EDP No.	TAP		D(Φ)	W(□)	L	EDP No.	TAP		D(Φ)	W(□)	L	EDP No.	TAP		D(Φ)	W(□)	L
	Inch	Metric					Inch	Metric					Inch	Metric			
11TC1411	#6	M3	0.141	0.110	0.472	16TC1411	#6	M3	0.141	0.110	0.709	20TC1411	#6	M3	0.141	0.110	0.709
11TC1613	#8	M4	0.168	0.131	0.472	16TC1613	#8	M4	0.168	0.131	0.709	20TC1613	#8	M4	0.168	0.131	0.709
11TC1915	#10	M4.5+M5	0.194	0.152	0.472	16TC1915	#10	M4.5+M5	0.194	0.152	0.709	20TC1915	#10	M4.5+M5	0.194	0.152	0.709
11TC2216	#12	-	0.220	0.165	0.551	16TC2216	#12	-	0.220	0.165	0.709	20TC2216	#12	-	0.220	0.165	0.709
11TC2519	1/4	M6	0.255	0.191	0.551	16TC2519	1/4	M6	0.255	0.191	0.709	20TC2519	1/4	M6	0.255	0.191	0.709
						16TC3123	5/16	M7+M8	0.318	0.238	0.709	20TC3123	5/16	M7+M8	0.318	0.238	0.866
						16TC3224	7/16	-	0.323	0.242	0.709	20TC3622	3/8	M10	0.367	0.275	0.866
												20TC3224	7/16	-	0.323	0.242	0.866
												20TC3828	1/2	M12	0.381	0.286	0.866
RD 25TC						RD 32TC						RD 40TC					
EDP No.	TAP		D(Φ)	W(□)	L	EDP No.	TAP		D(Φ)	W(□)	L	EDP No.	TAP		D(Φ)	W(□)	L
	Inch	Metric					Inch	Metric					Inch	Metric			
25TC1411	#6	M3	0.141	0.110	0.709	32TC1411	#6	M3	0.141	0.110	0.709	40TC1411	#6	M3	0.141	0.110	0.709
25TC1613	#8	M4	0.168	0.131	0.709	32TC1613	#8	M4	0.168	0.131	0.709	40TC1613	#8	M4	0.168	0.131	0.709
25TC1915	#10	M4.5+M5	0.194	0.152	0.709	32TC1915	#10	M4.5+M5	0.194	0.152	0.709	40TC1915	#10	M4.5+M5	0.194	0.152	0.709
25TC2216	#12	-	0.220	0.165	0.709	32TC2216	#12	-	0.220	0.165	0.709	40TC2216	#12	-	0.220	0.165	0.709
25TC2519	1/4	M6	0.255	0.191	0.709	32TC2519	1/4	M6	0.255	0.191	0.709	40TC2519	1/4	M6	0.255	0.191	0.709
25TC3123	5/16	M7+M8	0.318	0.238	0.866	32TC3123	5/16	M7+M8	0.318	0.238	0.866	40TC3123	5/16	M7+M8	0.318	0.238	0.866
25TC3622	3/8	M10	0.367	0.275	0.866	32TC3627	3/8	M10	0.367	0.275	0.866	40TC3627	3/8	M10	0.367	0.275	0.866
25TC3224	7/16	-	0.323	0.242	0.866	32TC3224	7/16	-	0.323	0.242	0.866	40TC3224	7/16	-	0.323	0.242	0.866
25TC3828	1/2	M12	0.381	0.286	0.866	32TC3828	1/2	M12	0.381	0.286	0.866	40TC3828	1/2	M12	0.381	0.286	0.866
25TC4232	9/16	M14	0.429	0.322	0.984	32TC4232	9/16	M14	0.429	0.322	0.984	40TC4232	9/16	M14	0.429	0.322	0.984
25TC4836	5/8	M16	0.480	0.360	0.984	32TC4836	5/8	M16	0.480	0.360	0.984	40TC4836	5/8	M16	0.480	0.360	0.984
25TC5440	11/16	M18	0.542	0.406	0.984	32TC5440	11/16	M18	0.542	0.406	0.984	40TC5440	11/16	M18	0.542	0.406	0.984
25TC5944	3/4	-	0.590	0.442	0.984	32TC5944	3/4	-	0.590	0.442	0.984	40TC5944	3/4	-	0.590	0.442	0.984
						32TC6548	13/16	M20	0.652	0.489	0.984	40TC6548	13/16	M20	0.652	0.489	0.984
												40TC6952	7/8	M22	0.697	0.523	0.984
												40TC7657	15/16	M24	0.760	0.570	0.984
												40TC8060	1	M25	0.800	0.600	1.102

TAP ER COLLET (INCH TYPE : ANSI)

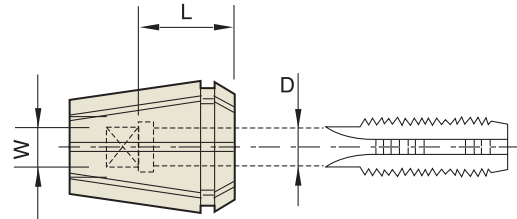

Below standard Tap ER Collet conforms to **ANSI** (For PIPE TAPS)

Unit : inch

RD 16TCP						RD 20TCP						RD 25TCP					
EDP No.	TAP		D(Φ)	W(□)	L	EDP No.	TAP		D(Φ)	W(□)	L	EDP No.	TAP		D(Φ)	W(□)	L
	Inch	Metric					Inch	Metric					Inch	Metric			
16TP3123	1/8(SS)	-	0.312	0.234	0.709	20TP3123	1/8(SS)	-	0.312	0.234	0.787	25TP3123	1/8(SS)	-	0.312	0.234	0.787
16TP4332	1/8(LS)	-	0.437	0.328	0.709	20TP4332	1/8(LS)	-	0.437	0.328	0.787	25TP4332	1/8(LS)	-	0.437	0.328	0.787
												25TP5642	1/4	-	0.562	0.420	0.787
RD 32TCP						RD 40TCP											
EDP No.	TAP		D(Φ)	W(□)	L	EDP No.	TAP		D(Φ)	W(□)	L						
	Inch	Metric					Inch	Metric									
32TP3123	1/8(SS)	-	0.312	0.234	0.787	40TP3123	1/8(SS)	-	0.312	0.234	0.787						
32TP4332	1/8(LS)	-	0.437	0.328	0.787	40TP4332	1/8(LS)	-	0.437	0.328	0.787						
32TP5642	1/4	-	0.562	0.420	0.787	40TP5642	1/4	-	0.562	0.420	0.787						
						40TP7053	3/8	-	0.700	0.530	0.866						
						40TP6851	1/2	-	0.687	0.515	0.866						
						40TP9067	3/4	-	0.906	0.679	0.945						

* SS : Short Series / LS : Long Series

TAP ER COLLET (METRIC TYPE : JIS)

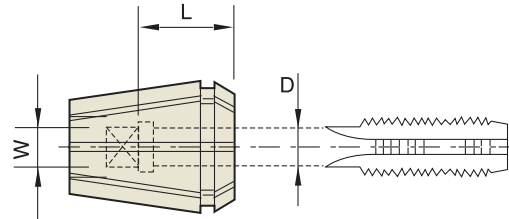

ER Collet
Chuck

Below standard Tap ER Collet conforms to **JIS**

Unit : mm

RDT 16					RDT 20					RDT 25					RDT 32					RDT 40											
EDP No.	TAP	D(Φ)	W(□)	L	EDP No.	TAP	D(Φ)	W(□)	L	EDP No.	TAP	D(Φ)	W(□)	L	EDP No.	TAP	D(Φ)	W(□)	L	EDP No.	TAP	D(Φ)	W(□)	L							
16T30025	M2	3.0	2.5	15																											
16T40032	M3	4.0	3.2	15	20T40032	M3	4.0	3.2	15	25T40032	M3	4.0	3.2	15																	
16T50040	M4	5.0	4.0	15	20T50040	M4	5.0	4.0	15	25T50032	M4	5.0	4.0	15	32T50040	M4	5.0	4.0	15												
16T55045	M5	5.5	4.5	15	20T55045	M5	5.5	4.5	15	25T55045	M5	5.5	4.5	15	32T55045	M5	5.5	4.5	15												
16T60045	M6	6.0	4.5	15	20T60045	M6	6.0	4.5	15	25T60045	M6	6.0	4.5	15	32T60045	M6	6.0	4.5	15												
16T62050	M8	6.2	5.0	15	20T62050	M8	6.2	5.0	20	25T62050	M8	6.2	5.0	20	32T62050	M8	6.2	5.0	20						40T62050	M8	6.2	5.0	20		
					20T70055	M10	7.0	5.5	20	25T70055	M10	7.0	5.5	20	32T70055	M10	7.0	5.5	20								40T70055	M10	7.0	5.5	20
										25T85065	M12	8.5	6.5	20	32T85065	M12	8.5	6.5	20								40T85065	M12	8.5	6.5	25
										25T10580	M14	10.5	8.0	20	32T10560	M14	10.5	8.0	20								40T10580	M14	10.5	8.0	25
															32T12510	M16	12.5	10.0	20							40T12510	M16	12.5	10.0	25	
															32T14011	M18	14.0	11.0	20							40T14011	M18	14.0	11.0	25	
																										40T15012	M20	15.0	12.0	28	
																										40T17013	M22	17.0	13.0	28	
																										40T19015	M24	19.0	15.0	28	

TAP ER COLLET (METRC TYPE : DIN)

ER Collet
Chuck

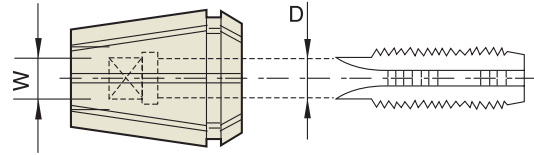

Below standard Tap ER Collet conforms to **DIN**

Unit : mm

DIN STANDARD			RD 11TCD			RD 16TCD			RD 20TCD		
DIN 374/376	DIN 352/2181	DIN 371	EDP No.	D(Ø)	W(□)	EDP No.	D(Ø)	W(□)	EDP No.	D(Ø)	W(□)
M5	M3	M3	11TD3527	3.5	2.7	16TD3527	3.5	2.7	20TD3527	3.5	2.7
M5.5	M3.5	M3.5	11TD4030	4.0	3.0	16TD4030	4.0	3.0	20TD4030	4.0	3.0
M6	M4	M4	11TD4534	4.5	3.4	16TD4534	4.5	3.4	20TD4534	4.5	3.4
M5	-	-	11TD5040	5.0	4.0	16TD5040	5.0	4.0	20TD5040	5.0	4.0
M7	-	-	11TD5543	5.5	4.3	16TD5543	5.5	4.3	20TD5543	5.5	4.3
M8	M4.5-M8	M4.5-M8	11TD6049	6.0	4.9	16TD6049	6.0	4.9	20TD6049	6.0	4.9
M9+M10	M9+M10	M7				16TD7055	7.0	5.5	20TD7055	7.0	5.5
M11	M11	M8							20TD8062	8.0	6.2
M12	M12	M9							20TD9070	9.0	7.0
-	-	M10							20TD10080	10.0	8.0
M13+M14	M13+M14	-									
M15-M17	M15-M17	-									
M18+M19	M18+M19	-									
M20+M21	M20+M21	-									
M22-M26	M22-M26	-									
M27+M28	M27+M28	-									
M29-M32	M29-M32	-									
M33	M33	-									
M34-M38	M34-M38	-									
M39-M42	M39-M42	-									

TAP ER COLLET (METRC TYPE : DIN)

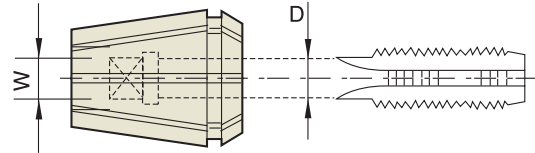

ER Collet
Chuck

Below standard Tap ER Collet conforms to **DIN**

Unit : mm

RD 25TCD			RD 32TCD			RD 40TCD			RD 50TCD		
EDP No.	D(∅)	W(□)	EDP No.	D(∅)	W(□)	EDP No.	D(∅)	W(□)	EDP No.	D(∅)	W(□)
25TD3527	3.5	2.7	32TD3527	3.5	2.7	40TD3527	3.5	2.7			
25TD4030	4.0	3.0	32TD4030	4.0	3.0	40TD4030	4.0	3.0			
25TD4534	4.5	3.4	32TD4534	4.5	3.4	40TD4534	4.5	3.4			
25TD5040	5.0	4.0	32TD5040	5.0	4.0	40TD5040	5.0	4.0			
25TD5543	5.5	4.3	32TD5543	5.5	4.3	40TD5543	5.5	4.3			
25TD6049	6.0	4.9	32TD6049	6.0	4.9	40TD6049	6.0	4.9			
25TD7055	7.0	5.5	32TD7055	7.0	5.5	40TD7055	7.0	5.5			
25TD8062	8.0	6.2	32TD8062	8.0	6.2	40TD8062	8.0	6.2	50TD8062	8.0	6.2
25TD9080	9.0	7.0	32TD9070	9.0	7.0	40TD9070	9.0	7.0	50TD9070	9.0	7.0
25TD10090	10.0	8.0	32TD10080	10.0	8.0	40TD10080	10.0	8.0	50TD10080	10.0	8.0
25TD11090	11.0	9.0	32TD11090	11.0	9.0	40TD11090	11.0	9.0	50TD11090	11.0	9.0
25TD12090	12.0	9.0	32TD12090	12.0	9.0	40TD12090	12.0	9.0	50TD12090	12.0	9.0
25TD140110	14.0	11.0	32TD140110	14.0	11.0	40TD140110	14.0	11.0	50TD140110	14.0	11.0
25TD160120	16.0	12.0	32TD160120	16.0	12.0	40TD160120	16.0	12.0	50TD160120	16.0	12.0
						40TD180145	18.0	14.5	50TD180145	18.0	14.5
						40TD200160	20.0	16.0	50TD200160	20.0	16.0
						40TD220180	22.0	18.0	50TD220180	22.0	18.0
									50TD250200	25.0	20.0
									50TD280220	28.0	22.0
									50TD320240	32.0	24.0

Rotary Tooling



**THE WORLD LEADER IN
THE TOOL HOLDER INDUSTRY**

-
- HYDRAULIC CHUCK
 - SHRINK FIT HOLDER
 - END MILL HOLDER & SIDE LOCK ARBOR
 - ER COLLET CHUCK
 - SK SLIM CHUCK
 - TG COLLET CHUCK
 - POWER MILLING CHUCK
 - MORSE TAPER ADAPTER
 - TAPPING CHUCK
 - SHELL MILL ARBOR
 - NC DRILL CHUCK
 - JACOBS TAPER ARBOR
 - STUB ARBOR
 - SLITTING SAW ARBOR
 - PULL STUD & TOOL CLAMP
-





ROTARY TOOLING

SK SLIM CHUCK



DUAL CONTACT SK SLIM CHUCK

CAT : ASME B5.50-200

CCT : CAT DUAL CONTACT

CBT : BT DUAL CONTACT

HSK : DIN 69893/ISO 12164-1

STRAIGHT SK SLIM CHUCK

STRAIGHT-K

ACCESSORY & PART

- SK COLLET

SK SLIM CHUCK

CAT

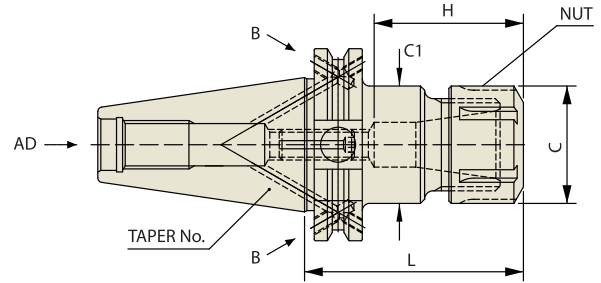

ASME B5.50 -CAT	Taper Accuracy AT3	G Value 2.5	RPM 25,000	Coolant System AD/B
--------------------	-----------------------	----------------	---------------	------------------------

ASME B5.50-2009- CAT

Unit : inch

EDP No.	TAPER No.	MODEL No.	CLAMPING RANGE	L	C	C1	H		COLLET	
							Min.	Max.		
TK020	40	CAT40AD/B-SKA6-3.54	0.036 - 0.236	3.540	0.787	0.768	0.827	1.378	SKC6	
TK021		CAT40AD/B-SKA6-4.72	0.036 - 0.236	4.720	0.787	0.768	0.827	1.378	SKC6	
TK022		CAT40AD/B-SKA6-5.90	0.036 - 0.236	5.900	0.787	0.768	0.827	1.378	SKC6	
TK023		CAT40AD/B-SKA10-3.54	0.068 - 0.394	3.540	1.102	1.083	1.181	1.969	SKC10	
TK024		CAT40AD/B-SKA10-4.72	0.068 - 0.394	4.720	1.102	1.083	1.181	1.969	SKC10	
TK025		CAT40AD/B-SKA10-5.90	0.068 - 0.394	5.900	1.102	1.083	1.181	1.969	SKC10	
TK026		CAT40AD/B-SKA13-3.54	0.108 - 0.512	3.540	1.299	1.299	1.220	2.559	SKC13	
TK027		CAT40AD/B-SKA13-4.72	0.108 - 0.512	4.720	1.299	1.299	1.220	2.559	SKC13	
TK028		CAT40AD/B-SKA13-5.90	0.108 - 0.512	5.900	1.299	1.299	1.220	2.559	SKC13	
TK029		CAT40AD/B-SKA16-3.54	0.108 - 0.630	3.540	1.575	1.575	1.772	2.756	SKC16	
TK030		CAT40AD/B-SKA16-4.72	0.108 - 0.630	4.720	1.575	1.575	1.772	2.756	SKC16	
TK031		CAT40AD/B-SKA16-5.90	0.108 - 0.630	5.900	1.575	1.575	1.772	2.756	SKC16	
TK032		CAT40AD/B-SKA20-3.54	0.138 - 0.787	3.540	1.909	1.909	1.850	3.150	SKC20	
TK033		CAT40AD/B-SKA20-4.72	0.138 - 0.787	4.720	1.909	1.909	1.850	3.150	SKC20	
TK034		CAT40AD/B-SKA20-5.90	0.138 - 0.787	5.900	1.909	1.909	1.850	3.150	SKC20	
TK035		CAT40AD/B-SKA25-3.54	0.630 - 1.000	3.540	2.165	2.165	2.165	3.346	SKC25	
TK036		CAT40AD/B-SKA25-4.72	0.630 - 1.000	4.720	2.165	2.165	2.165	3.346	SKC25	
TK037		CAT40AD/B-SKA25-5.90	0.630 - 1.000	5.900	2.165	2.165	2.165	3.346	SKC25	
TL020		50	CAT50AD/B-SKA6-4.13	0.036 - 0.236	4.130	0.787	0.768	0.827	1.378	SKC6
TL021			CAT50AD/B-SKA6-5.31	0.036 - 0.236	5.310	0.787	0.768	0.827	1.378	SKC6
TL022	CAT50AD/B-SKA6-6.50		0.036 - 0.236	6.500	0.787	0.768	0.827	1.378	SKC6	
TL023	CAT50AD/B-SKA6-7.68		0.036 - 0.236	7.680	0.787	0.768	0.827	1.378	SKC6	
TL024	CAT50AD/B-SKA10-4.13		0.068 - 0.394	4.130	1.102	1.083	1.181	1.969	SKC10	
TL025	CAT50AD/B-SKA10-5.31		0.068 - 0.394	5.310	1.102	1.083	1.181	1.969	SKC10	
TL026	CAT50AD/B-SKA10-6.50		0.068 - 0.394	6.500	1.102	1.083	1.181	1.969	SKC10	
TL027	CAT50AD/B-SKA10-7.68		0.068 - 0.394	7.680	1.102	1.083	1.181	1.969	SKC10	
TL028	CAT50AD/B-SKA13-4.13		0.108 - 0.512	4.130	1.299	1.299	1.220	2.559	SKC13	
TL029	CAT50AD/B-SKA13-5.31		0.108 - 0.512	5.310	1.299	1.299	1.220	2.559	SKC13	
TL030	CAT50AD/B-SKA13-6.50		0.108 - 0.512	6.500	1.299	1.299	1.220	2.559	SKC13	
TL031	CAT50AD/B-SKA13-7.68		0.108 - 0.512	7.680	1.299	1.299	1.220	2.559	SKC13	
TL032	CAT50AD/B-SKA16-4.13		0.108 - 0.630	4.130	1.575	1.575	1.772	2.362	SKC16	
TL033	CAT50AD/B-SKA16-5.31		0.108 - 0.630	5.310	1.575	1.575	1.772	2.756	SKC16	
TL034	CAT50AD/B-SKA16-6.50		0.108 - 0.630	6.500	1.575	1.575	1.772	2.756	SKC16	
TL035	CAT50AD/B-SKA16-7.68		0.108 - 0.630	7.680	1.575	1.575	1.772	2.756	SKC16	
TL036	CAT50AD/B-SKA20-4.13		0.138 - 0.787	4.130	1.909	1.909	1.850	3.150	SKC20	
TL037	CAT50AD/B-SKA20-5.31		0.138 - 0.787	5.310	1.909	1.909	1.850	3.150	SKC20	
TL038	CAT50AD/B-SKA20-6.50		0.138 - 0.787	6.500	1.909	1.909	1.850	3.150	SKC20	
TL039	CAT50AD/B-SKA20-7.68		0.138 - 0.787	7.680	1.909	1.909	1.850	3.150	SKC20	
TL040	CAT50AD/B-SKA25-4.13		0.630 - 1.000	4.130	2.165	2.165	2.165	3.346	SKC25	
TL041	CAT50AD/B-SKA25-5.31		0.630 - 1.000	5.310	2.165	2.165	2.165	3.346	SKC25	
TL042	CAT50AD/B-SKA25-6.50		0.630 - 1.000	6.500	2.165	2.165	2.165	3.346	SKC25	
TL043	CAT50AD/B-SKA25-7.68	0.630 - 1.000	7.680	2.165	2.165	2.165	3.346	SKC25		

* SK collet on page 93~95.

DUAL CONTACT SK SLIM CHUCK

CCT

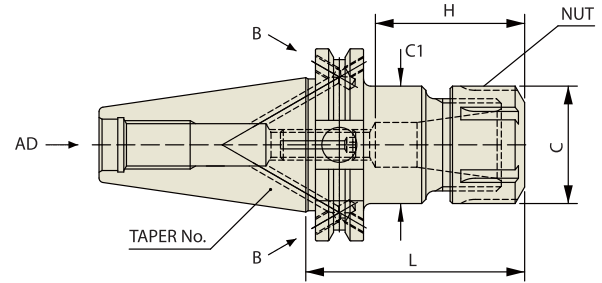

CCT	Taper Accuracy AT3	G Value 2.5	RPM 25,000	Coolant System AD/B
-----	------------------------------	-----------------------	----------------------	-------------------------------

SK Slim
Chuck

CCT (CAT DUAL CONTACT)

Unit : inch

EDP No.	TAPER No.	MODEL No.	CLAMPING RANGE	L	C	C1	H		COLLET	
							Min.	Max.		
TB020	40	CCT40AD/B-SKA6-3.54	0.036 - 0.236	3.540	0.787	0.768	0.827	1.378	SKC6	
TB021		CCT40AD/B-SKA6-4.72	0.036 - 0.236	4.720	0.787	0.768	0.827	1.378	SKC6	
TB022		CCT40AD/B-SKA6-5.90	0.036 - 0.236	5.900	0.787	0.768	0.827	1.378	SKC6	
TB023		CCT40AD/B-SKA10-3.54	0.068 - 0.394	3.540	1.102	1.083	1.181	1.969	SKC10	
TB024		CCT40AD/B-SKA10-4.72	0.068 - 0.394	4.720	1.102	1.083	1.181	1.969	SKC10	
TB025		CCT40AD/B-SKA10-5.90	0.068 - 0.394	5.900	1.102	1.083	1.181	1.969	SKC10	
TB026		CCT40AD/B-SKA13-3.54	0.108 - 0.512	3.540	1.299	1.299	1.220	2.559	SKC13	
TB027		CCT40AD/B-SKA13-4.72	0.108 - 0.512	4.720	1.299	1.299	1.220	2.559	SKC13	
TB028		CCT40AD/B-SKA13-5.90	0.108 - 0.512	5.900	1.299	1.299	1.220	2.559	SKC13	
TB029		CCT40AD/B-SKA16-3.54	0.108 - 0.630	3.540	1.575	1.575	1.772	2.756	SKC16	
TB030		CCT40AD/B-SKA16-4.72	0.108 - 0.630	4.720	1.575	1.575	1.772	2.756	SKC16	
TB031		CCT40AD/B-SKA16-5.90	0.108 - 0.630	5.900	1.575	1.575	1.772	2.756	SKC16	
TB032		CCT40AD/B-SKA20-3.54	0.138 - 0.787	3.540	1.909	1.909	1.850	3.150	SKC20	
TB033		CCT40AD/B-SKA20-4.72	0.138 - 0.787	4.720	1.909	1.909	1.850	3.150	SKC20	
TB034		CCT40AD/B-SKA20-5.90	0.138 - 0.787	5.900	1.909	1.909	1.850	3.150	SKC20	
TB035		CCT40AD/B-SKA25-3.54	0.630 - 1.000	3.540	2.165	2.165	2.165	3.346	SKC25	
TB036		CCT40AD/B-SKA25-4.72	0.630 - 1.000	4.720	2.165	2.165	2.165	3.346	SKC25	
TB037		CCT40AD/B-SKA25-5.90	0.630 - 1.000	5.900	2.165	2.165	2.165	3.346	SKC25	
TC020		50	CCT50AD/B-SKA6-4.13	0.036 - 0.236	4.130	0.787	0.768	0.827	1.378	SKC6
TC021			CCT50AD/B-SKA6-5.31	0.036 - 0.236	5.310	0.787	0.768	0.827	1.378	SKC6
TC022	CCT50AD/B-SKA6-6.50		0.036 - 0.236	6.500	0.787	0.768	0.827	1.378	SKC6	
TC023	CCT50AD/B-SKA6-7.68		0.036 - 0.236	7.680	0.787	0.768	0.827	1.378	SKC6	
TC024	CCT50AD/B-SKA10-4.13		0.068 - 0.394	4.130	1.102	1.083	1.181	1.969	SKC10	
TC025	CCT50AD/B-SKA10-5.31		0.068 - 0.394	5.310	1.102	1.083	1.181	1.969	SKC10	
TC026	CCT50AD/B-SKA10-6.50		0.068 - 0.394	6.500	1.102	1.083	1.181	1.969	SKC10	
TC027	CCT50AD/B-SKA10-7.68		0.068 - 0.394	7.680	1.102	1.083	1.181	1.969	SKC10	
TC028	CCT50AD/B-SKA13-4.13		0.108 - 0.512	4.130	1.299	1.299	1.220	2.559	SKC13	
TC029	CCT50AD/B-SKA13-5.31		0.108 - 0.512	5.310	1.299	1.299	1.220	2.559	SKC13	
TC030	CCT50AD/B-SKA13-6.50		0.108 - 0.512	6.500	1.299	1.299	1.220	2.559	SKC13	
TC031	CCT50AD/B-SKA13-7.68		0.108 - 0.512	7.680	1.299	1.299	1.220	2.559	SKC13	
TC032	CCT50AD/B-SKA16-4.13		0.108 - 0.630	4.130	1.575	1.575	1.772	2.362	SKC16	
TC033	CCT50AD/B-SKA16-5.31		0.108 - 0.630	5.310	1.575	1.575	1.772	2.756	SKC16	
TC034	CCT50AD/B-SKA16-6.50		0.108 - 0.630	6.500	1.575	1.575	1.772	2.756	SKC16	
TC035	CCT50AD/B-SKA16-7.68		0.108 - 0.630	7.680	1.575	1.575	1.772	2.756	SKC16	
TC036	CCT50AD/B-SKA20-4.13		0.138 - 0.787	4.130	1.909	1.909	1.850	3.150	SKC20	
TC037	CCT50AD/B-SKA20-5.31		0.138 - 0.787	5.310	1.909	1.909	1.850	3.150	SKC20	
TC038	CCT50AD/B-SKA20-6.50		0.138 - 0.787	6.500	1.909	1.909	1.850	3.150	SKC20	
TC039	CCT50AD/B-SKA20-7.68		0.138 - 0.787	7.680	1.909	1.909	1.850	3.150	SKC20	
TC040	CCT50AD/B-SKA25-4.13		0.630 - 1.000	4.130	2.165	2.165	2.165	3.346	SKC25	
TC041	CCT50AD/B-SKA25-5.31		0.630 - 1.000	5.310	2.165	2.165	2.165	3.346	SKC25	
TC042	CCT50AD/B-SKA25-6.50		0.630 - 1.000	6.500	2.165	2.165	2.165	3.346	SKC25	
TC043	CCT50AD/B-SKA25-7.68	0.630 - 1.000	7.680	2.165	2.165	2.165	3.346	SKC25		

* SK collet on page 93~95.

DUAL CONTACT SK SLIM CHUCK

CBT

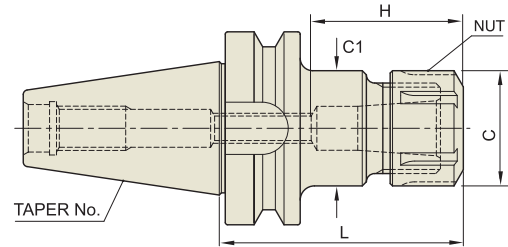

CBT	Taper Accuracy AT3	G Value 2.5	RPM 25,000	Coolant System AD
-----	------------------------------	-----------------------	----------------------	-----------------------------

CBT (BT DUAL CONTACT)

Unit : mm

EDP No.	TAPER No.	MODEL No.	CLAMPING RANGE	L	C	C1	H		COLLET
							Min.	Max.	
TD100	30	CBT30-SKA06-60	0.9 - 6.0	60	20	19.5	21	35	SKC6
TD102		CBT30-SKA06-90	0.9 - 6.0	90	20	19.5	21	35	SKC6
TD104		CBT30-SKA10-60	1.75 - 10.0	60	28	27.5	30	50	SKC10
TD106		CBT30-SKA10-90	1.75 - 10.0	90	28	27.5	30	50	SKC10
TD108		CBT30-SKA13-60	2.75 - 13.0	60	33	33	31	65	SKC13
TD110		CBT30-SKA13-90	2.75 - 13.0	90	33	33	31	65	SKC13
TD112		CBT30-SKA16-60	2.75 - 16.0	60	40	40	45	60	SKC16
TD114		CBT30-SKA16-90	2.75 - 16.0	90	40	40	45	60	SKC16
TD116		CBT30-SKA20-60	4.0 - 20.0	60	48.5	48.5	65	75	SKC20
TD118		CBT30-SKA20-90	4.0 - 20.0	90	48.5	48.5	65	75	SKC20
TD120		CBT30-SKA25-90	16.0 - 25.4	90	55	55	55	75	SKC25
TE100		40	CBT40-SKA06-90	0.9 - 6.0	90	20	19.5	21	35
TE102	CBT40-SKA06-120		0.9 - 6.0	120	20	19.5	21	35	SKC6
TE104	CBT40-SKA06-150		0.9 - 6.0	150	20	19.5	21	35	SKC6
TE106	CBT40-SKA10-90		1.75 - 10.0	90	28	27.5	30	50	SKC10
TE108	CBT40-SKA10-120		1.75 - 10.0	120	28	27.5	30	50	SKC10
TE110	CBT40-SKA10-150		1.75 - 10.0	150	28	27.5	30	50	SKC10
TE112	CBT40-SKA13-90		2.75 - 13.0	90	33	33	31	65	SKC13
TE114	CBT40-SKA13-120		2.75 - 13.0	120	33	33	31	65	SKC13
TE116	CBT40-SKA13-150		2.75 - 13.0	150	33	40	31	65	SKC13
TE118	CBT40-SKA16-90		2.75 - 16.0	90	40	40	45	70	SKC16
TE121	CBT40-SKA16-120		2.75 - 16.0	120	40	40	45	70	SKC16
TE122	CBT40-SKA16-150		2.75 - 16.0	150	40	40	45	70	SKC16
TE124	CBT40-SKA20-90		4.0 - 20.0	90	48.5	48.5	47	80	SKC20
TE126	CBT40-SKA20-120		4.0 - 20.0	120	48.5	48.5	47	80	SKC20
TE128	CBT40-SKA20-150	4.0 - 20.0	150	48.5	48.5	47	80	SKC20	
TE130	CBT40-SKA25-90	16.0 - 25.4	90	55	55	55	85	SKC25	
TE132	CBT40-SKA25-120	16.0 - 25.4	120	55	55	55	85	SKC25	
TE134	CBT40-SKA25-150	16.0 - 25.4	150	55	55	55	85	SKC25	

* SK collet on page 93~95.

DUAL CONTACT SK SLIM CHUCK

HSK

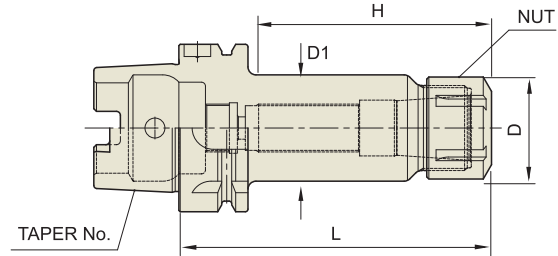

DIN 69893
- HSK

Taper
Accuracy
-

G Value
2.5

RPM
25,000

Coolant
System
AD

SK Slim
Chuck

DIN 69893/ISO 12164-1-HSK FORM A

Unit : mm

EDP No.	TAPER No.	MODEL No.	CLAMPING RANGE	D	D1	L	H		COLLET
							Min.	Max.	
TQ100	63A	HSK63A-SKA06-100	0.75 - 6.0	20	19.5	100	21	35	SKC6
TQ102		HSK63A-SKA10-100	1.75 - 10.0	28	27.5	100	30	50	SKC10
TQ104		HSK63A-SKA13-100	2.75 - 13.0	33	33	100	31	65	SKC13
TQ106		HSK63A-SKA16-120	2.75 - 16.0	40	40	120	45	70	SKC16
TQ108		HSK63A-SKA20-120	4.0 - 20.0	48.5	48.5	120	65	75	SKC20
TQ110		HSK63A-SKA25-150	16.0 - 25.4	55	55	150	55	85	SKC25
TR100	100A	HSK100A-SKA06-120	0.75 - 6.0	20	19.5	120	21	35	SKC6
TR102		HSK100A-SKA10-150	1.75 - 10.0	28	27.5	150	30	50	SKC10
TR104		HSK100A-SKA13-150	2.75 - 13.0	33	40	150	31	65	SKC13
TR106		HSK100A-SKA16-150	2.75 - 16.0	40	40	150	45	70	SKC16
TR108		HSK100A-SKA20-150	4.0 - 20.0	48.5	48.5	150	65	75	SKC20
TR110		HSK100A-SKA25-160	16.0 - 25.4	55	55	160	55	85	SKC25

* SK collet on page 93~95.

STRAIGHT SK SLIM CHUCK

K

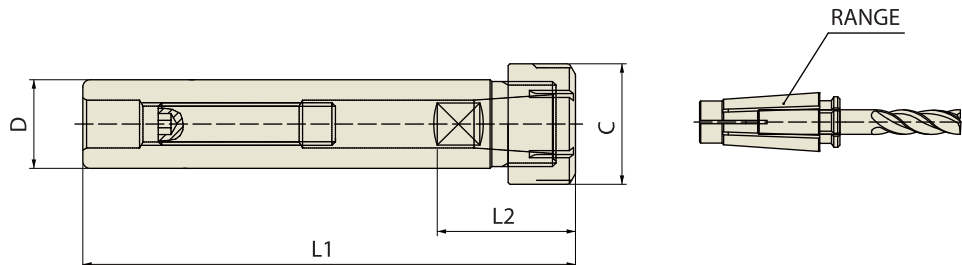

STRAIGHT-K

Unit : inch

EDP No.	TAPER No.	MODEL No.	D	C	L1	L2
TS020	K3/4	K3/4-SKA6-100	0.750	0.787	3.937	0.827-1.378
TS021		K3/4-SKA6-140	0.750	0.787	5.512	0.827-1.378
TS022		K3/4-SKA10-100	0.750	1.102	3.937	1.181-1.969
TS023		K3/4-SKA10-140	0.750	1.102	5.512	1.181-1.969
TS030	K1	K1-SKA6-100	1.000	0.787	3.937	0.827-1.378
TS031		K1-SKA6-140	1.000	0.787	5.512	0.827-1.378
TS032		K1-SKA10-100	1.000	1.102	3.937	1.181-1.969
TS033		K1-SKA10-150	1.000	1.102	5.906	1.181-1.969
TS034		K1-SKA13-100	1.000	1.299	3.937	1.220-2.559
TS035		K1-SKA13-150	1.000	1.299	5.906	1.220-2.559
TS040	K1 1/4	K1 1/4-SKA10-100	1.250	1.102	3.937	1.181-1.969
TS041		K1 1/4-SKA10-150	1.250	1.102	5.906	1.181-1.969
TS042		K1 1/4-SKA13-100	1.250	1.299	3.937	1.220-2.559
TS043		K1 1/4-SKA13-150	1.250	1.299	5.906	1.220-2.559
TS044		K1 1/4-SKA16-100	1.250	1.575	3.937	1.575-2.756
TS045		K1 1/4-SKA16-150	1.250	1.575	5.906	1.575-2.756
TS046		K1 1/4-SKA20-100	1.250	1.909	3.937	1.850-3.150
TS047	K1 1/4-SKA20-150	1.250	1.909	5.906	1.850-3.150	

* SK collet on page 93~95.

SK COLLET (METRIC TYPE)

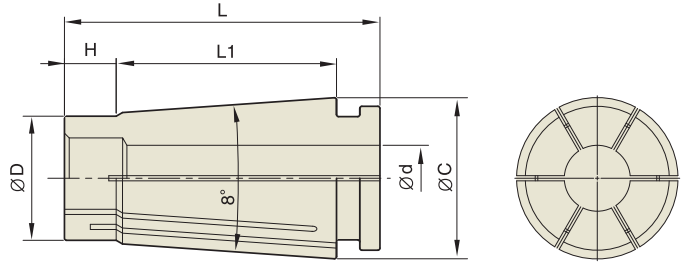

◇ T.I.R of standard collet is 5Um at 3D.

Unit : mm

EDP No.	TYPE	MODEL No.	CLAMPING RANGE (d)	EDP No.	TYPE	MODEL No.	CLAMPING RANGE (d)	EDP No.	TYPE	MODEL No.	CLAMPING RANGE (d)
306010	SKC6	SKC6 - 1	0.9 - 1.0	310020	SKC10	SKC10 - 2	1.75 - 2.0	313030	SKC13	SKC13 - 3	2.75 - 3.0
306015		SKC6 - 1.5	1.3 - 1.5	310025		SKC10 - 2.5	2.25 - 2.5	313035		SKC13 - 3.5	3.0 - 3.5
306020		SKC6 - 2	1.8 - 2.0	310030		SKC10 - 3	2.75 - 3.0	313040		SKC13 - 4	3.5 - 4.0
306025		SKC6 - 2.5	2.3 - 2.5	310035		SKC10 - 3.5	3.0 - 3.5	313045		SKC13 - 4.5	4.0 - 4.5
306030		SKC6 - 3	2.8 - 3.0	310040		SKC10 - 4	3.5 - 4.0	313050		SKC13 - 5	4.5 - 5.0
306035		SKC6 - 3.5	3.0 - 3.5	310045		SKC10 - 4.5	4.0 - 4.5	313055		SKC13 - 5.5	5.0 - 5.5
306040		SKC6 - 4	3.5 - 4.0	310050		SKC10 - 5	4.5 - 5.0	313060		SKC13 - 6	5.5 - 6.0
306045		SKC6 - 4.5	4.0 - 4.5	310055		SKC10 - 5.5	5.0 - 5.5	313065		SKC13 - 6.5	6.0 - 6.5
306050		SKC6 - 5	4.5 - 5.0	310060		SKC10 - 6	5.5 - 6.0	313070		SKC13 - 7	6.5 - 7.0
306055		SKC6 - 5.5	5.0 - 5.5	310065		SKC10 - 6.5	6.0 - 6.5	313075		SKC13 - 7.5	7.0 - 7.5
306060	SKC6 - 6	5.5 - 6.0	310070	SKC10 - 7	6.5 - 7.0	313080	SKC13 - 8	7.5 - 8.0			
			310075	SKC10 - 7.5	7.0 - 7.5	313085	SKC13 - 8.5	8.0 - 8.5			
			310080	SKC10 - 8	7.5 - 8.0	313090	SKC13 - 9	8.5 - 9.0			
			310085	SKC10 - 8.5	8.0 - 8.5	313095	SKC13 - 9.5	9.0 - 9.5			
			310090	SKC10 - 9	8.5 - 9.0	313100	SKC13 - 10	9.5 - 10.0			
			310095	SKC10 - 9.5	9.0 - 9.5	313105	SKC13 - 10.5	10.0 - 10.5			
			310100	SKC10 - 10	9.5 - 10.0	313110	SKC13 - 11	10.5 - 11.0			
						313115	SKC13 - 11.5	11.0 - 11.5			
						313120	SKC13 - 12	11.5 - 12.0			
						313125	SKC13 - 12.5	12.0 - 12.5			
						313130	SKC13 - 13	12.5 - 13.0			

SKC COLLET Dimension

Unit : mm

TYPE	D	L	L1	H	C
SKC6	7.5	25.7	17.6	3.8	10
SKC10	12	32	21.3	5	15
SKC13	15.4	39	28.3	5.5	20
SKC16	18.8	46	32	8	24
SKC20	22.5	54.2	41	8	29
SKC25	28.9	58.2	43	8.5	35

SK COLLET (METRIC TYPE)

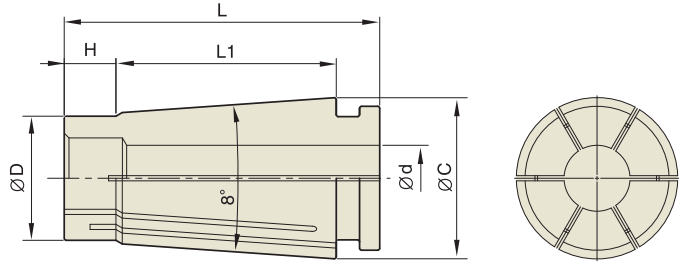

◇ T.I.R of standard collet is 5Um at 3D.

Unit : mm

EDP No.	TYPE	MODEL No.	CLAMPING RANGE (d)	EDP No.	TYPE	MODEL No.	CLAMPING RANGE (d)	EDP No.	TYPE	MODEL No.	CLAMPING RANGE (d)
316030	SKC16	SKC16-3	2.75 - 3.0	323040	SKC20	SKC20-4	3.5 - 4.0	325165	SKC25	SKC25-16.5	16.0 - 16.5
316035		SKC16-3.5	3.0 - 3.5	323045		SKC20-4.5	4.0 - 4.5	325170		SKC25-17	16.5 - 17.0
316040		SKC16-4	3.5 - 4.0	323050		SKC20-5	4.5 - 5.0	325175		SKC25-17.5	17.0 - 17.5
316045		SKC16-4.5	4.0 - 4.5	323055		SKC20-5.5	5.0 - 5.5	325180		SKC25-18	17.5 - 18.0
316050		SKC16-5	4.5 - 5.0	323060		SKC20-6	5.5 - 6.0	325185		SKC25-18.5	18.0 - 18.5
316055		SKC16-5.5	5.0 - 5.5	323065		SKC20-6.5	6.0 - 6.5	325190		SKC25-19	18.5 - 19.0
316060		SKC16-6	5.5 - 6.0	323070		SKC20-7	6.5 - 7.0	325195		SKC25-19.5	19.0 - 19.5
316605		SKC16-6.5	6.0 - 6.5	323075		SKC20-7.5	7.0 - 7.5	325200		SKC25-20	19.5 - 20.0
316070		SKC16-7	6.5 - 7.0	323080		SKC20-8	7.5 - 8.0	325205		SKC25-20.5	20.0 - 20.5
316075		SKC16-7.5	7.0 - 7.5	323085		SKC20-8.5	8.0 - 8.5	325210		SKC25-21	20.5 - 21.0
316080		SKC16-8	7.5 - 8.0	323090		SKC20-9	8.5 - 9.0	325215		SKC25-21.5	21.0 - 21.5
316085		SKC16-8.5	8.0 - 8.5	323095		SKC20-9.5	9.0 - 9.5	325220		SKC25-22	21.5 - 22.0
316090		SKC16-9	8.5 - 9.0	323100		SKC20-10	9.5 - 10.0	325225		SKC25-22.5	22.0 - 22.5
316095		SKC16-9.5	9.0 - 9.5	323105		SKC20-10.5	10.0 - 10.5	325230		SKC25-23	22.5 - 23.0
316100		SKC16-10	9.5 - 10.0	323110		SKC20-11	10.5 - 11.0	325235		SKC25-23.5	23.0 - 23.5
316105		SKC16-10.5	10.0 - 10.5	323115		SKC20-11.5	11.0 - 11.5	325240		SKC25-24	23.5 - 24.0
316110	SKC16-11	10.5 - 11.0	323120	SKC20-12	11.5 - 12.0	325245	SKC25-24.5	24.0 - 24.5			
316115	SKC16-11.5	10.0 - 11.5	323125	SKC20-12.5	12.0 - 12.5	325250	SKC25-25	24.5 - 25.0			
316120	SKC16-12	11.5 - 12.0	323130	SKC20-13	12.5 - 13.0	325254	SKC25-25.4	25.0 - 25.4			
316125	SKC16-12.5	12.0 - 12.5	323135	SKC20-13.5	13.0 - 13.5						
316130	SKC16-13	12.5 - 13.0	323140	SKC20-14	13.5 - 14.0						
316135	SKC16-13.5	13.0 - 13.5	323145	SKC20-14.5	14.0 - 14.5						
316140	SKC16-14	13.5 - 14.0	323150	SKC20-15	14.5 - 15.0						
316145	SKC16-14.5	14.0 - 14.5	323155	SKC20-15.5	15.0 - 15.5						
316150	SKC16-15	14.5 - 15.0	323160	SKC20-16	15.5 - 16.0						
316155	SKC16-15.5	15.0 - 15.5	323165	SKC20-16.5	16.0 - 16.5						
316160	SKC16-16	15.5 - 16.0	323170	SKC20-17	16.5 - 17.0						
			323175	SKC20-17.5	17.0 - 17.5						
			323180	SKC20-18	17.5 - 18.0						
			323185	SKC20-18.5	18.0 - 18.5						
			323190	SKC20-19	18.5 - 19.0						
			323195	SKC20-19.5	19.0 - 19.5						
			323200	SKC20-20.0	19.5 - 20.0						

SK COLLET (INCH TYPE)

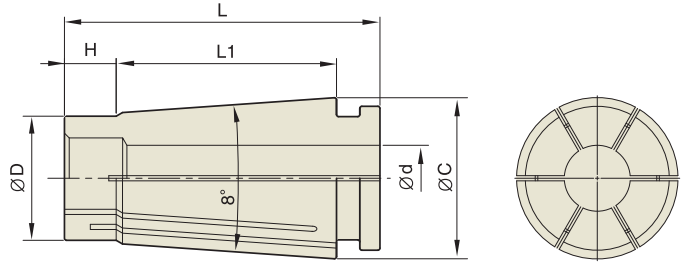

◇ T.I.R of standard collet is 5Um at 3D.

Unit : inch

EDP No.	TYPE	MODEL No.	CLAMPING RANGE (d1)
3060108A	SKC6	SKC6-1/8A	0.125
3060316A		SKC6-3/16A	0.187

EDP No.	TYPE	MODEL No.	CLAMPING RANGE (d1)
3100108A	SKC10	SKC10-1/8A	0.125
3100316A		SKC10-3/16A	0.187
3100104A		SKC10-1/4A	0.25
3100516A		SKC10-5/16A	0.312
3100308A		SKC10-3/8A	0.375

EDP No.	TYPE	MODEL No.	CLAMPING RANGE (d1)
3160108A	SKC16	SKC16-1/8A	0.125
3160316A		SKC16-3/16A	0.187
3160104A		SKC16-1/4A	0.25
3160516A		SKC16-5/16A	0.312
3160308A		SKC16-3/8A	0.375
3160716A		SKC16-7/16A	0.437
3160102A		SKC16-1/2A	0.5
3160916A		SKC16-9/16A	0.562
3160508A		SKC16-5/8A	0.625

EDP No.	TYPE	MODEL No.	CLAMPING RANGE (d1)
3250316A	SKC25	SKC25-3/16A	0.187
3250104A		SKC25-1/4A	0.25
3250516A		SKC25-5/16A	0.312
3250308A		SKC25-3/8A	0.375
3250716A		SKC25-7/16A	0.437
3250102A		SKC25-1/2A	0.5
3250508A		SKC25-5/8A	0.625
3250304A		SKC25-3/4A	0.75

Rotary Tooling



**THE WORLD LEADER IN
THE TOOL HOLDER INDUSTRY**

-
- HYDRAULIC CHUCK
 - SHRINK FIT HOLDER
 - END MILL HOLDER & SIDE LOCK ARBOR
 - ER COLLET CHUCK
 - SK SLIM CHUCK
 - TG COLLET CHUCK
 - POWER MILLING CHUCK
 - MORSE TAPER ADAPTER
 - TAPPING CHUCK
 - SHELL MILL ARBOR
 - NC DRILL CHUCK
 - JACOBS TAPER ARBOR
 - STUB ARBOR
 - SLITTING SAW ARBOR
 - PULL STUD & TOOL CLAMP
-





ROTARY TOOLING

TG COLLET CHUCK



TG COLLET CHUCK

CAT : ASME B5.50-2009

BT : JIS B6339/MAS 403

ACCESSORY & PART

- TG NUT / TG WRENCH / TG STOP SCREW

TG COLLET CHUCK

CAT

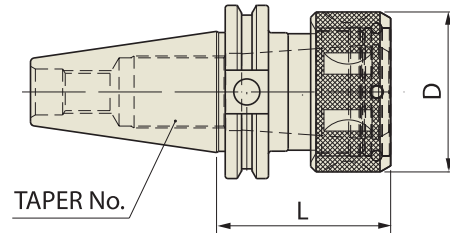

ASME B5.50 - CAT	Taper Accuracy AT3	G Value -	RPM -	Coolant System AD
---------------------	-----------------------	--------------	----------	----------------------

ASME B5.50-2009-CAT

TG75

■ STANDARD

Unit : inch

EDP No.	TAPER No.	MODEL No.	CLAMPING RANGE	L	D	COLLET SERIES
VK012	40	CAT40-TG75-2.50	0.047 - 0.750	2.50	1.81	75TG

■ EXTENDED

Unit : inch

EDP No.	TAPER No.	MODEL No.	CLAMPING RANGE	L	D	COLLET SERIES
VK312	40	CAT40-TG75-3.00	0.047 - 0.750	3.00	1.81	75TG

TG100

■ STANDARD

Unit : inch

EDP No.	TAPER No.	MODEL No.	CLAMPING RANGE	L	D	COLLET SERIES
OK014	40	CAT40-TG100-3.25	0.063 - 1.000	3.25	2.36	100TG
OL014	50	CAT50-TG100-3.25	0.063 - 1.000	3.25	2.36	100TG

■ EXTENDED

Unit : inch

EDP No.	TAPER No.	MODEL No.	CLAMPING RANGE	L	D	COLLET SERIES
OK314	40	CAT40-TG100-4.50	0.063 - 1.000	4.50	2.36	100TG
OL314	50	CAT50-TG100-5.50	0.063 - 1.000	5.50	2.36	100TG

TG150

■ STANDARD

Unit : inch

EDP No.	TAPER No.	MODEL No.	CLAMPING RANGE	L	D	COLLET SERIES
UL052	50	CAT50-TG150-3.50	0.500 - 1.500	3.50	3.43	150TG

■ EXTENDED

Unit : inch

EDP No.	TAPER No.	MODEL No.	CLAMPING RANGE	L	D	COLLET SERIES
UL352	50	CAT50-TG150-6.00	0.500 - 1.500	6.00	3.43	150TG

* TG Nut : Swiss made precision TG Nut
* Wrenches on page 100.

TG COLLET CHUCK

BT

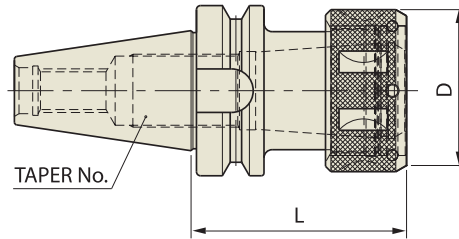

JIS B6339/MAS 403-BT

TG75

■ STANDARD

Unit : inch

EDP No.	TAPER No.	MODEL No.	CLAMPING RANGE	L	D	COLLET SERIES
VH012	40	BT40-TG75-3.00	0.047 - 0.750	3.00	1.81	75TG

JIS B6339 -BT	Taper Accuracy AT3	G Value -	RPM -	Coolant System AD
------------------	-----------------------	--------------	----------	----------------------

TG100

■ STANDARD

Unit : inch

EDP No.	TAPER No.	MODEL No.	CLAMPING RANGE	L	D	COLLET SERIES
OH014	40	BT40-TG100-3.50	0.063 - 1.000	3.50	2.36	100TG
OI014	50	BT50-TG100-3.50	0.063 - 1.000	3.50	2.36	100TG

■ EXTENDED

Unit : mm

EDP No.	TAPER No.	MODEL No.	CLAMPING RANGE	L	D	COLLET SERIES
OH314	40	BT40-TG100-5.50	0.063 - 1.000	5.50	2.36	100TG
OI314	50	BT50-TG100-6.00	0.063 - 1.000	6.00	2.36	100TG

TG150

■ STANDARD

Unit : inch

EDP No.	TAPER No.	MODEL No.	CLAMPING RANGE	L	D	COLLET SERIES
UI052	50	BT50-TG150-4.00	0.500 - 1.500	4.00	3.43	150TG

■ EXTENDED

Unit : inch

EDP No.	TAPER No.	MODEL No.	CLAMPING RANGE	L	D	COLLET SERIES
UI352	50	BT50-TG150-6.00	0.500 - 1.500	6.00	3.43	150TG

* TG Nut : Swiss made precision TG Nut

* Wrenches on page 100.

TG NUT

TG NUT

EDP No.	SERIES
ZZ084	TG75-NUT
ZZ081	TG100-NUT
ZZ087	TG150-NUT

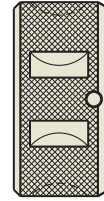

TG WRENCH

TG WRENCH

EDP No.	SERIES
ZZ085	TG75
ZZ082	TG100
ZZ088	TG150



TG STOP SCREW

TG STOP SCREW

EDP No.	SERIES
ZZ086	TG75
ZZ083	TG100
ZZ089	TG150

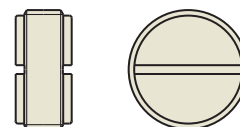



ROTARY TOOLING

POWER MILLING CHUCK



POWER MILLING CHUCK

CAT : ASME B5.50-2009

BT : JIS B6339/MAS 403

DUAL CONTACT HIGH SPEED POWER MILLING CHUCK

CCT : CAT DUAL CONTACT

CBT : BT DUAL CONTACT

HSK : DIN 69893/ISO 12164-1

ACCESSORY & PART

- MILLING CHUCK COLLET / WRENCH

POWER MILLING CHUCK

CAT

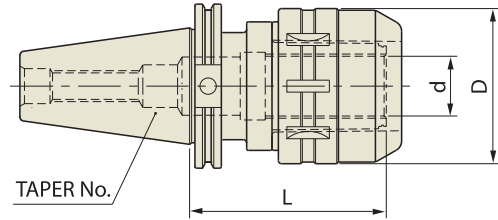

ASME B5.50 -CAT	Taper Accuracy AT3	G Value -	RPM -	Coolant System AD
--------------------	-----------------------	--------------	----------	----------------------

ASME B5.50-2009-CAT

STANDARD

Unit : inch

EDP No.	TAPER No.	MODEL No.	d	D	L
LK010	40	CAT40-C3/4-4.13	0.750	2.126	4.13
LK014		CAT40-C1"-4.13	1.000	2.461	4.13
LK017		CAT40-C1 1/4-4.13	1.250	2.835	4.13
LL010	50	CAT50-C3/4-4.13	0.750	2.126	4.13
LL014		CAT50-C1"-4.13	1.000	2.461	4.13
LL017		CAT50-C1 1/4-4.13	1.250	2.835	4.13

* Collets / Wrenches for Power Milling Chucks on page 106.

POWER MILLING CHUCK

BT

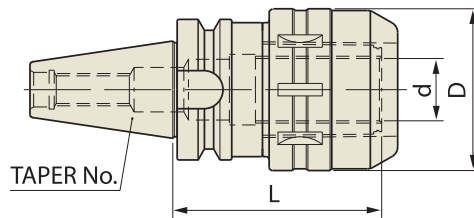

JIS B6339 -BT	Taper Accuracy AT3	G Value -	RPM -	Coolant System AD
------------------	-----------------------	--------------	----------	----------------------

JIS B6339/MAS 403-BT

STANDARD

Unit : inch

EDP No.	TAPER No.	MODEL No.	d	D	L
LH010	40	BT40-C3/4-3.56	0.750	2.126	3.56
LH014		BT40-C1"-4.13	1.000	2.461	4.13
LH017		BT40-C1 1/4-4.13	1.250	2.835	4.13
LI010	50	BT50-C3/4-4.13	0.750	2.126	4.13
LI014		BT50-C1"-4.13	1.000	2.461	4.13
LI017		BT50-C1 1/4-4.13	1.250	2.835	4.13

* Collets / Wrenches for Power Milling Chucks on page 106.

DUAL CONTACT HIGH SPEED POWER MILLING CHUCK

CCT

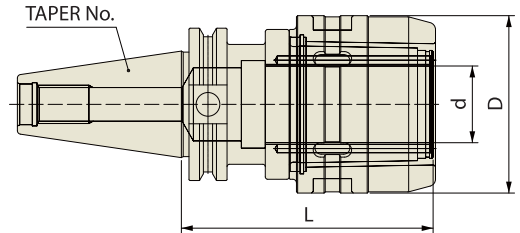

CCT	Taper Accuracy AT3	G Value 6.3	RPM 20,000	Coolant System AD
-----	------------------------------	-----------------------	----------------------	-----------------------------

CCT (CAT DUAL CONTACT)

Unit : inch

EDP No.	TAPER No.	MODEL No.	d	D	L
LB020	40	CCT40-C3/4-4.13HS	0.750	2.126	4.13
LB022		CCT40-C1"-4.13HS	1.000	2.461	4.13
LB024		CCT40-C1 1/4-4.13HS	1.250	2.835	4.13
LB026		CCT40-C1 1/4-5.31HS	1.250	2.835	5.31
LC020	50	CCT50-C3/4-4.13HS	0.750	2.126	4.13
LC022		CCT50-C1"-4.13HS	1.000	2.461	4.13
LC024		CCT50-C1 1/4-4.13HS	1.250	2.835	4.13
LC026		CCT50-C1 1/4-5.31HS	1.250	2.835	5.31
LC028		CCT50-C1 1/4-6.5HS	1.250	2.835	6.50

* Collets / Wrenches for Power Milling Chucks on page 106.

Power Milling
Chuck

DUAL CONTACT HIGH SPEED POWER MILLING CHUCK

CBT

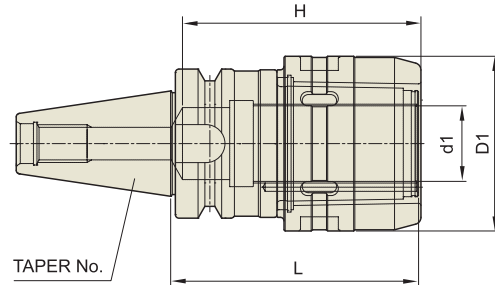

CBT	Taper Accuracy AT3	G Value 6.3	RPM 20,000	Coolant System AD
-----	------------------------------	-----------------------	----------------------	-----------------------------

CBT (BT DUAL CONTACT)

Unit : inch

EDP No.	TAPER No.	MODEL No.	d1	D1	L
LE020	40	CBT40-C3/4-3.15HS	0.750	2.126	3.15
LE022		CBT40-C3/4-4.13HS	0.750	2.126	4.13
LE024		CBT40-C1"-4.13HS	1.000	2.461	4.13
LE026		CBT40-C1 1/4-3.54HS	1.250	2.835	3.54
LE028		CBT40-C1 1/4-4.13HS	1.250	2.835	4.13
LE030		CBT40-C1 1/4-5.31HS	1.250	2.835	5.31

* Collets / Wrenches for Power Milling Chucks on page 106.

Power Milling
Chuck

DUAL CONTACT HIGH SPEED POWER MILLING CHUCK

HSK

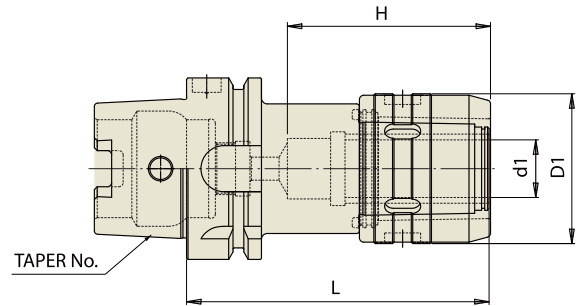

DIN 69893 - HSK	Taper Accuracy -	G Value 6.3	RPM 20,000	Coolant System AD
---------------------------	----------------------------	-----------------------	----------------------	-----------------------------

DIN 69893/ISO 12164-1-HSK FORM A

Unit : inch

EDP No.	TAPER No.	MODEL No.	d1	D1	L
LQ020	63A	HSK63A-C3/4-4.13HS	0.750	2.126	4.13
LQ022		HSK63A-C1"-4.72HS	1.000	2.461	4.72
LQ024		HSK63A-C1 1/4-5.31HS	1.250	2.835	5.31
LR020	100A	HSK100A-C3/4-4.33HS	0.750	2.126	4.33
LR022		HSK100A-C1"-5.12HS	1.000	2.461	5.12
LR024		HSK100A-C1 1/4-5.31HS	1.250	2.835	5.31

* Collets / Wrenches for Power Milling Chucks on page 106.

Power Milling
Chuck

POWER MILLING CHUCK COLLET

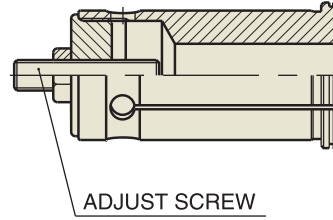

Unit : inch

EDP No.	TYPE	D
MZ002	C3/4	1/4
MZ003	C3/4	5/16
MZ004	C3/4	3/8
MZ006	C3/4	1/2
MZ008	C3/4	5/8

Unit : inch

EDP No.	TYPE	D
MZ102	C1	1/4
MZ103	C1	5/16
MZ104	C1	3/8
MZ106	C1	1/2
MZ108	C1	5/8
MZ110	C1	3/4

Unit : inch

EDP No.	TYPE	D
MZ302	C1 1/4	1/4
MZ303	C1 1/4	5/16
MZ304	C1 1/4	3/8
MZ306	C1 1/4	1/2
MZ308	C1 1/4	5/8
MZ310	C1 1/4	3/4
MZ312	C1 1/4	7/8
MZ314	C1 1/4	1"

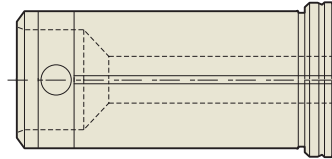

Unit : inch

EDP No.	TYPE	D
MY002	C3/4	1/4
MY003	C3/4	5/16
MY004	C3/4	3/8
MY006	C3/4	1/2
MY008	C3/4	5/8

Unit : inch

EDP No.	TYPE	D
MY102	C1	1/4
MY103	C1	5/16
MY104	C1	3/8
MY106	C1	1/2
MY108	C1	5/8
MY110	C1	3/4

Unit : inch

EDP No.	TYPE	D
MY302	C1 1/4	1/4
MY303	C1 1/4	5/16
MY304	C1 1/4	3/8
MY306	C1 1/4	1/2
MY308	C1 1/4	5/8
MY310	C1 1/4	3/4
MY312	C1 1/4	7/8
MY314	C1 1/4	1"

WRENCH

Unit : inch

EDP No.	SERIES
ZZ056	C3/4
ZZ057	C1
ZZ058	C1 1/4





ROTARY TOOLING

MORSE TAPER ADAPTER



MORSE TAPER ADAPTER

CAT : ASME B5.50-2009

BT : JIS B6339/MAS 403

MORSE TAPER ADAPTER

CAT

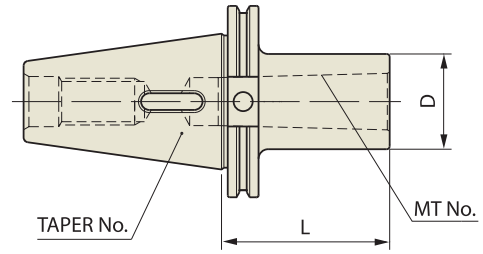

ASME B5.50 - CAT	Taper Accuracy AT3	G Value 6.3	RPM 15,000	Coolant System AD
---------------------	------------------------------	-----------------------	----------------------	-----------------------------

ASME B5.50-2009-CAT

Unit : inch

EDP No.	TAPER No.	MODEL No.	MT No.	D	L
CK037	40	CAT40-MTA1-1.75	#1	1.00	1.75
CK038		CAT40-MTA2-2.00	#2	1.26	2.00
CK039		CAT40-MTA3-2.75	#3	1.75	2.75
CK040		CAT40-MTA4-3.63	#4	1.75	3.63
CL038	50	CAT50-MTA2-1.38	#2	2.75	1.38
CL039		CAT50-MTA3-1.88	#3	1.57	1.88
CL040		CAT50-MTA4-2.75	#4	1.97	2.75
CL041		CAT50-MTA5-4.06	#5	2.48	4.06

MORSE TAPER ADAPTER

BT

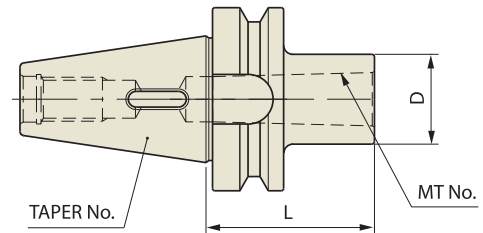

JIS B6339 - BT	Taper Accuracy AT3	G Value 6.3	RPM 15,000	Coolant System AD
-------------------	------------------------------	-----------------------	----------------------	-----------------------------

JIS B6339/MAS 403-BT

Unit : inch

EDP No.	TAPER No.	MODEL No.	MT No.	D	L
CH037	40	BT40-MTA1-1.75	#1	1.00	1.75
CH038		BT40-MTA2-2.36	#2	1.26	2.36
CH039		BT40-MTA3-2.95	#3	1.57	2.95
CH040		BT40-MTA4-3.74	#4	1.97	3.74
CI038	50	BT50-MTA2-2.36	#2	1.26	2.36
CI039		BT50-MTA3-2.95	#3	1.58	2.95
CI040		BT50-MTA4-3.74	#4	1.97	3.74
CI041		BT50-MTA5-4.13	#5	2.55	4.13



ROTARY TOOLING

TAPPING CHUCK



TAPPING CHUCK

CAT : ASME B5.50-2009

BT : JIS B6339/MAS 403

SYNCHRO TAPPING ER CHUCK

CAT : ASME B5.50-2009

ACCESSORY & PART

- QUICK CHANGE TAP ADAPTER

TAPPING CHUCK

CAT

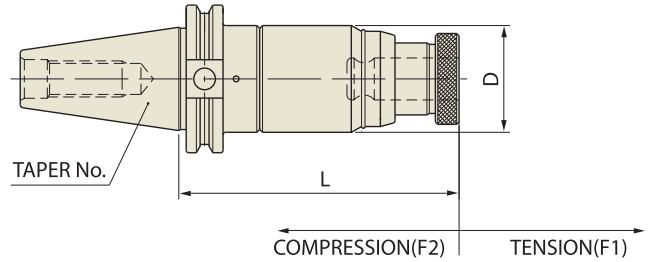

ASME B5.50 -CAT	Taper Accuracy AT3	G Value -	RPM -	Coolant System -
--------------------	--------------------------	--------------	----------	------------------------

ASME B5.50-2009-CAT

■ TO USE TAP ADAPTER QCT12

Unit : inch

EDP No.	TAPER No.	MODEL No.	D	L	F1	F2
JK048	40	CAT40-TC#1-4.56	1.77	4.56	0.591	0.197
JL048	50	CAT50-TC#1-4.56	1.77	4.56	0.591	0.197

■ TO USE TAP ADAPTER QCT24

Unit : inch

EDP No.	TAPER No.	MODEL No.	D	L	F1	F2
JK049	40	CAT40-TC#2-6.47	2.48	6.47	0.787	0.197
JL049	50	CAT50-TC#2-5.82	2.48	5.82	0.787	0.197

■ TO USE TAP ADAPTER QCT32

Unit : inch

EDP No.	TAPER No.	MODEL No.	D	L	F1	F2
JL050	50	CAT50-TC#3-7.75	3.86	7.75	0.984	0.394

* Tap Adapters are on page 113.

TAPPING CHUCK

BT

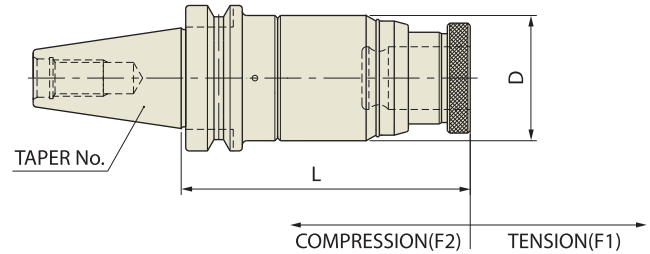

JIS B6339/MAS 403-BT

JIS B6339 -BT	Taper Accuracy AT3	G Value -	RPM -	Coolant System -
------------------	--------------------------	--------------	----------	------------------------

■ TO USE TAP ADAPTER QCT12

Unit : inch

EDP No.	TAPER No.	MODEL No.	D	L	F1	F2
JH048	40	BT40-TC#1-4.53	1.77	4.53	0.591	0.197
JI048	50	BT50-TC#1-4.64	1.77	4.64	0.591	0.197

■ TO USE TAP ADAPTER QCT24

Unit : inch

EDP No.	TAPER No.	MODEL No.	D	L	F1	F2
JH049	40	BT40-TC#2-6.72	2.48	6.72	0.787	0.197
JI049	50	BT50-TC#2-6.72	2.48	6.72	0.787	0.197

■ TO USE TAP ADAPTER QCT38

Unit : inch

EDP No.	TAPER No.	MODEL No.	D	L	F1	F2
JI050	50	BT50-TC#3-8.33	3.86	8.33	0.984	0.394

* Tap Adapters are on page 113.

Tapping
Chuck

SYNCHRO TAPPING ER CHUCK

CAT

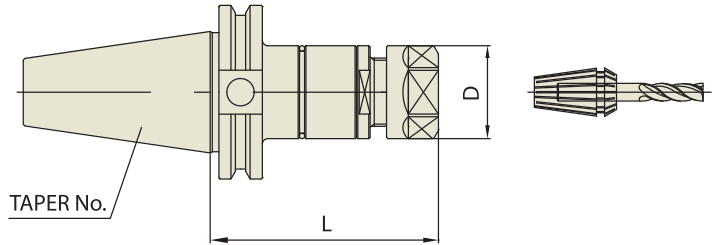

ASME B5.50 -CAT	Taper Accuracy AT3	G Value -	RPM -	Coolant System AD/B
--------------------	--------------------------	--------------	----------	---------------------------

ASME B5.50-2009-CAT

Unit : mm

EDP No.	TAPER No.	MODEL No.	TAP SIZE	CLAMPING RANGE	NUT	D	L
JK060SYT	40	CAT40AD/B-SYTER12-79	M3-M12	3.5 - 10	ER16	28	79
JK062SYT		CAT40AD/B-SYTER16-85	M3-M16	3.5 - 10	ER20	35	85
JK064SYT		CAT40AD/B-SYTER20-90	M3-M20	3.5 - 16	ER25	42	90
JK066SYT		CAT40AD/B-SYTER27-100	M4-M27	3.5 - 16	ER32	50	100
JK068SYT		CAT40AD/B-SYTER33-105	M4-M33	7 - 16	ER40	63	105
JL060SYT	50	CAT50AD/B-SYTER12-79	M3-M12	3.5 - 10	ER16	28	79
JL062SYT		CAT50AD/B-SYTER16-85	M3-M16	3.5 - 10	ER20	35	85
JL064SYT		CAT50AD/B-SYTER20-90	M3-M20	3.5 - 16	ER25	42	90
JL066SYT		CAT50AD/B-SYTER27-100	M4-M27	3.5 - 16	ER32	50	100
JL068SYT		CAT50AD/B-SYTER33-105	M4-M33	7 - 16	ER40	63	105

* BT(JIS B6339/MAS-403), HSK(DIN 69893/ISO 12164-1) and STRAIGHT-K Taper products are available.

For details, please discuss separately.

* Applicable TAP ER collets on page 81~85.

Feature

- To compensate for synchronization errors to extend tap life and to improve thread quality
- To compensate for pitch tolerances of taps
- For machine with synchronized spindle

QUICK CHANGE TAP ADAPTER

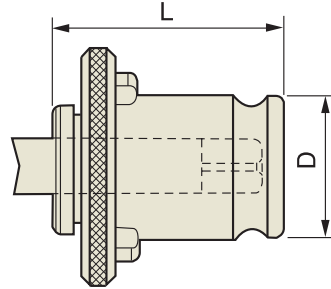

POSITIVE DRIVE-SOLID TYPE

Unit : inch

EDP No.	ADAPTER SIZE	TAP SIZE RANGE	TAP SIZE	TAP Dia.	TAP SQUARE	
QCT12001	QCT 12 D = 19mm/0.748" L = 28.5mm/1.122"	0-9/16"	# 0-6	0.141	0.110	
QCT12002			# 8	0.168	0.131	
QCT12003			# 10	0.194	0.152	
QCT12004			# 12	0.220	0.165	
QCT12005			1/4	0.255	0.191	
QCT12006			5/16	0.318	0.238	
QCT12007			3/8	0.381	0.286	
QCT12008			7/16	0.323	0.242	
QCT12009			1/2	0.367	0.275	
QCT12010			9/16	0.429	0.322	
QCT12011			1/8" PIPE	1/8pss	0.3125	0.234
QCT12012				1/8pls	0.4370	0.328
QCT24001	QCT 24 D = 31mm/1.220" L = 46mm/1.811"	5/16-7/8"	5/16	0.318	0.238	
QCT24002			3/8	0.381	0.286	
QCT24003			7/16	0.323	0.242	
QCT24004			1/2	0.367	0.275	
QCT24005			9/16	0.429	0.322	
QCT24006			5/8	0.480	0.360	
QCT24007			11/16	0.542	0.406	
QCT24008			3/4	0.590	0.421	
QCT24009			13/16	0.652	0.489	
QCT24010			7/8	0.697	0.523	
QCT24011			1/4"-3/8" 1/2" PIPE	1/4p	0.5620	0.42
QCT24012				3/8p	0.7000	0.531
QCT24013				1/2p	0.6875	0.515
QCT32001	QCT 32 D = 48mm/1.890" L = 69.5mm/2.736"	13/16-1-3/8"	13/16	0.652	0.489	
QCT32002			7/8	0.697	0.523	
QCT32003			15/16	0.760	0.570	
QCT32004			1	0.800	0.600	
QCT32005			1-1/8	0.896	0.672	
QCT32006			1-1/4	1.021	0.766	
QCT32007			1-3/8	1.108	0.831	
QCT32008			1/2-3/4 & 1" PIPE	1/2p	0.6875	0.515
QCT32009				3/4p	0.9060	0.679
QCT32010				1p	1.1250	0.843

Rotary Tooling



**THE WORLD LEADER IN
THE TOOL HOLDER INDUSTRY**

-
- HYDRAULIC CHUCK
 - SHRINK FIT HOLDER
 - END MILL HOLDER & SIDE LOCK ARBOR
 - ER COLLET CHUCK
 - SK SLIM CHUCK
 - TG COLLET CHUCK
 - POWER MILLING CHUCK
 - MORSE TAPER ADAPTER
 - TAPPING CHUCK
 - SHELL MILL ARBOR
 - NC DRILL CHUCK
 - JACOBS TAPER ARBOR
 - STUB ARBOR
 - SLITTING SAW ARBOR
 - PULL STUD & TOOL CLAMP
-





ROTARY TOOLING

SHELL MILL ARBOR



SHELL MILL ARBOR

CAT : ASME B5.50-2009

BT : JIS B6339/MAS 403

DUAL CONTACT SHELL MILL ARBOR

CCT : CAT DUAL CONTACT

CBT : BT DUAL CONTACT

ACCESSORY & PART

- SHELL MILL DRIVE KEY / SHELL MILL LOCK SCREW

SHELL MILL ARBOR

CAT

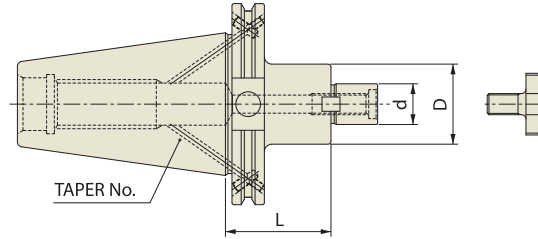

ASME B5.50
-CAT

Taper
Accuracy
AT3

G Value
6.3

RPM
15,000

Coolant
System
AD/B

ASME B5.50-2009-CAT

■ STANDARD

Unit : inch

EDP No.	TAPER No.	MODEL No.	d	L	D
EK006B	40	CAT40AD/B-SMA1/2-1.50	0.500	1.50	1.44
EK010B		CAT40AD/B-SMA3/4-1.50	0.750	1.50	1.69
EK014B		CAT40AD/B-SMA1"-2.00	1.000	2.00	2.19
EK017B		CAT40AD/B-SMA1 1/4-2.00	1.250	2.00	2.75
EK021B		CAT40AD/B-SMA1 1/2-3.00	1.500	3.00	3.81
EL010B	50	CAT50AD/B-SMA3/4-1.50	0.750	1.50	1.69
EL014B		CAT50AD/B-SMA1"-2.00	1.000	2.00	2.19
EL017B		CAT50AD/B-SMA1 1/4-2.00	1.250	2.00	2.75
EL021B		CAT50AD/B-SMA1 1/2-2.50	1.500	2.50	3.81
EL029B		CAT50AD/B-SMA2"-3.00	2.000	3.00	4.88

■ EXTENDED

Unit : inch

EDP No.	TAPER No.	MODEL No.	d	L	D
EK306B	40	CAT40AD/B-SMA1/2-3.50	0.500	3.50	1.44
EK310B		CAT40AD/B-SMA3/4-3.50	0.750	3.50	1.69
EK314B		CAT40AD/B-SMA1"-4.00	1.000	4.00	2.19
EK317B		CAT40AD/B-SMA1 1/4-4.00	1.250	4.00	2.75
EK321B		CAT40AD/B-SMA1 1/2-4.00	1.500	4.00	3.81
EL310B	50	CAT50AD/B-SMA3/4-3.50	0.750	3.50	1.69
EL314B		CAT50AD/B-SMA1"-4.00	1.000	4.00	2.19
EL317B		CAT50AD/B-SMA1 1/4-4.00	1.250	4.00	2.75
EL321B		CAT50AD/B-SMA1 1/2-4.00	1.500	4.00	3.81
EL329B		CAT50AD/B-SMA2"-4.00	2.000	4.00	4.88

* High balanced Shell Mill Arbors are available on request.
 * Drive Key / Lock Screw for Shell Mill Arbors on page 120.

SHELL MILL ARBOR

BT

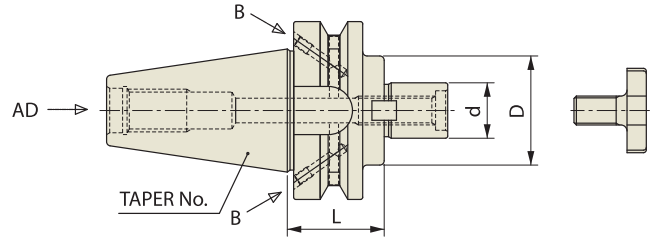

JIS B6339/MAS 403-BT

JIS B6339 -BT	Taper Accuracy AT3	G Value 6.3	RPM 15,000	Coolant System AD/B
------------------	--------------------------	----------------	---------------	---------------------------

STANDARD

Unit : inch

EDP No.	TAPER No.	MODEL No.	d	L	D
EH006B	40	BT40AD/B-SMA1/2-1.75	0.500	1.75	1.44
EH010B		BT40AD/B-SMA3/4-1.77	0.750	1.77	1.69
EH014B		BT40AD/B-SMA1"-1.77	1.000	1.77	2.19
EH017B		BT40AD/B-SMA1 1/4-1.81	1.250	1.81	2.75
EH021B		BT40AD/B-SMA1 1/2-2.36	1.500	2.36	3.81
EI010	50	BT50-SMA3/4-1.75	0.750	1.75	1.69
EI014		BT50-SMA1"-1.75	1.000	1.75	2.19
EI017		BT50-SMA1 1/4-1.75	1.250	1.75	2.75
EI021		BT50-SMA1/2-1.75	1.500	1.75	3.81
EI029		BT50-SMA2"-3.00	2.000	3.00	4.88

EXTENDED

Unit : inch

EDP No.	TAPER No.	MODEL No.	d	L	D
EH306B	40	BT40AD/B-SMA1/2-3.50	0.500	3.50	1.44
EH310B		BT40AD/B-SMA3/4-4.13	0.750	4.13	1.69
EH314B		BT40AD/B-SMA1"-4.13	1.000	4.13	2.19
EH317B		BT40AD/B-SMA1 1/4-4.13	1.250	4.13	2.75
EH321B		BT40AD/B-SMA1 1/2-4.72	1.500	4.72	3.81
EI310	50	BT50-SMA3/4-3.50	0.750	3.50	1.69
EI314		BT50-SMA1"-4.00	1.000	4.00	2.19
EI317		BT50-SMA1 1/4-4.00	1.250	4.00	2.75
EI321		BT50-SMA1 1/2-4.00	1.500	4.00	3.81
EI329		BT50-SMA2"-4.00	2.000	4.00	4.88

- * High balanced Shell Mill Arbors are available on request.
- * Drive Key / Lock Screw for Shell Mill Arbors on page 120.

DUAL CONTACT SHELL MILL ARBOR

CCT

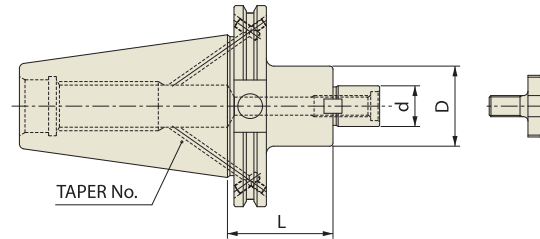

CCT	Taper Accuracy AT3	G Value 2.5	RPM 25,000	Coolant System AD/B
-----	-----------------------	----------------	---------------	------------------------

CCT (CAT DUAL CONTACT)

Unit : inch

EDP No.	TAPER No.	MODEL No.	d	D	L	
EB020	40	CCT40AD/B-SMA1/2-2.36	0.500	1.438	2.360	
EB022		CCT40AD/B-SMA1/2-4.72	0.500	1.438	4.720	
EB024		CCT40AD/B-SMA3/4-2.36	0.750	1.688	2.360	
EB026		CCT40AD/B-SMA3/4-4.72	0.750	1.688	4.720	
EB028		CCT40AD/B-SMA1"-2.36	1.000	2.188	2.360	
EB030		CCT40AD/B-SMA1"-4.72	1.000	2.188	4.720	
EB032		CCT40AD/B-SMA1 1/4-2.36	1.250	2.750	2.360	
EB034		CCT40AD/B-SMA1 1/4-4.72	1.250	2.750	4.720	
EC020		50	CCT50AD/B-SMA1/2-2.95	0.500	1.438	2.950
EC022			CCT50AD/B-SMA1/2-4.72	0.500	1.438	4.720
EC024	CCT50AD/B-SMA3/4-2.95		0.750	1.688	2.950	
EC026	CCT50AD/B-SMA3/4-4.72		0.750	1.688	4.720	
EC028	CCT50AD/B-SMA1"-2.95		1.000	2.188	2.950	
EC030	CCT50AD/B-SMA1"-4.72		1.000	2.188	4.720	
EC032	CCT50AD/B-SMA1 1/4-2.95		1.250	2.750	2.950	
EC034	CCT50AD/B-SMA1 1/4-4.72		1.250	2.750	4.720	
EC036	CCT50AD/B-SMA1 1/2-2.95		1.500	3.813	2.950	
EC038	CCT50AD/B-SMA1 1/2-4.72		1.500	3.813	4.720	

* Drive Key / Lock Screw for Shell Mill Arbors on page 120.

DUAL CONTACT SHELL MILL ARBOR

CBT

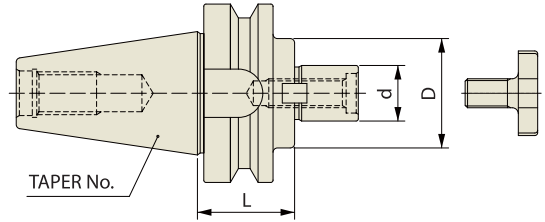

CBT	Taper Accuracy AT3	G Value 2.5	RPM 25,000	Coolant System AD
-----	------------------------------	-----------------------	----------------------	-----------------------------

CBT (BT DUAL CONTACT)

Unit : inch

EDP No.	TAPER No.	MODEL No.	d	D	L
ED100	30	CBT30-SMA1/2-1.97	0.500	1.438	1.970
ED102		CBT30-SMA3/4-1.97	0.750	1.688	1.970
ED104		CBT30-SMA1"-1.97	1.000	2.188	1.970
ED106		CBT30-SMA1 1/4-1.97	1.250	2.750	1.970
EE100	40	CBT40-SMA1/2-2.36	0.500	1.438	2.360
EE102		CBT40-SMA3/4-2.36	0.750	1.688	2.360
EE104		CBT40-SMA1"-2.36	1.000	2.188	2.360
EE106		CBT40-SMA1 1/4-2.36	1.250	2.750	2.360

* Drive Key / Lock Screw for Shell Mill Arbors on page 120.

SHELL MILL DRIVE KEY



SHELL MILL DRIVE KEY

Unit : inch

EDP No.	SERIES	B
ZZ021	SMA1/2-KEY	0.25
ZZ022	SMA3/4-KEY	0.312
ZZ023	SMA1"-KEY	0.375
ZZ024	SMA1 1/4-KEY	0.5
ZZ025	SMA1 1/2-KEY	0.625
ZZ026	SMA2"-KEY	0.75

SHELL MILL LOCK SCREW

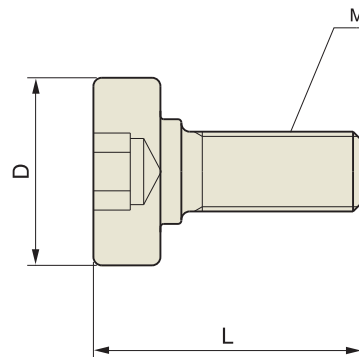

SHELL MILL LOCK SCREW

Unit : inch

EDP No.	TYPE (M)	L	D	SERIES
ZZ031	UNF1/4-28	0.906	0.618	SMA1/2-SCREW
ZZ032	UNF3/8-24	1.26	0.882	SMA3/4-SCREW
ZZ033	UNF1/2-20	1.69	1.181	SMA1"-SCREW
ZZ034	UNF5/8-18	2.05	1.5	SMA1 1/4-SCREW
ZZ035	UNF3/4-16	2.36	1.88	SMA1 1/2-SCREW
ZZ036	UN1"-14	2.52	2.5	SMA2"-SCREW



ROTARY TOOLING

NC DRILL CHUCK



NC DRILL CHUCK

CAT : ASME B5.50-2009

BT : JIS B6339/MAS 403

DUAL CONTACT NC DRILL CHUCK

HSK : DIN 69893/ISO 12164-1

STRAIGHT NC DRILL CHUCK

STRAIGHT-K

NC DRILL CHUCK

CAT

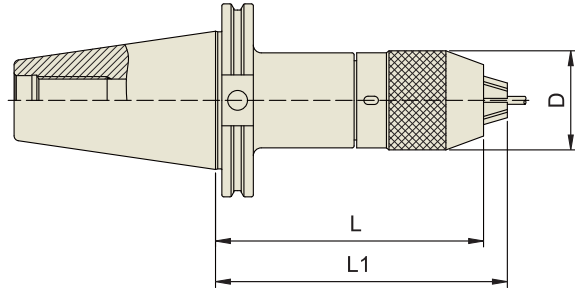

ASME B5.50 -CAT	Taper Accuracy AT3	G Value -	RPM -	Coolant System -
--------------------	--------------------------	--------------	----------	------------------------

ASME B5.50-2009-CAT

Unit : inch

EDP No.	TAPER No.	MODEL No.	RANGE	D	L	L1
RK020	40	CAT40-NPU8-2.95	0.012 - 0.315	1.437	2.950	3.174
RK022		CAT40-NPU8-4.33	0.012 - 0.315	1.437	4.331	4.555
RK024		CAT40-NPU8-5.91	0.012 - 0.315	1.437	5.906	6.130
RK026		CAT40-NPU13-3.54	0.039 - 0.512	1.984	3.543	3.937
RK028		CAT40-NPU13-5.12	0.039 - 0.512	1.984	5.118	5.512
RK030		CAT40-NPU13-5.91	0.039 - 0.512	1.984	5.906	6.299
RL020		50	CAT50-NPU8-3.54	0.012 - 0.315	1.437	3.543
RL022	CAT50-NPU8-4.33		0.012 - 0.315	1.437	4.331	4.555
RL024	CAT50-NPU8-6.69		0.012 - 0.315	1.437	6.693	6.917
RL026	CAT50-NPU13-3.94		0.039 - 0.512	1.984	3.937	4.331
RL028	CAT50-NPU13-5.12		0.039 - 0.512	1.984	5.118	5.512
RL030	CAT50-NPU13-5.91		0.039 - 0.512	1.984	5.906	6.299
RL032	CAT50-NPU13-6.69		0.039 - 0.512	1.984	6.693	7.087

NC DRILL CHUCK

BT

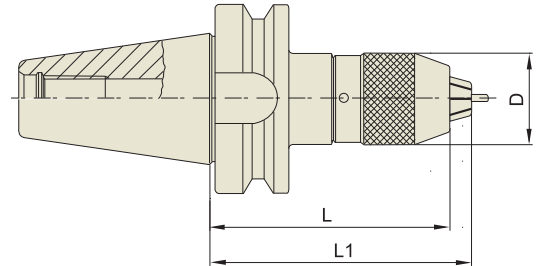

JIS B6339 -BT	Taper Accuracy AT3	G Value -	RPM -	Coolant System -
------------------	--------------------------	--------------	----------	------------------------

JIS B6339/MAS 403-BT

Unit : mm

EDP No.	TAPER No.	MODEL No.	RANGE	D	L(Min.)	L1(Max.)
RG100	30	BT30-NPU8-75	0.3 - 8	36.5	75	80.7
RG102		BT30-NPU13-105	1 - 13	50.4	105	115
RH100	40	BT40-NPU8-80	0.3 - 8	36.5	80	85.7
RH102		BT40-NPU8-110	0.3 - 8	36.5	110	115.7
RH104		BT40-NPU8-150	0.3 - 8	36.5	150	155.7
RH106		BT40-NPU13-95	1 - 13	50.4	95	100.7
RH108		BT40-NPU13-130	1 - 13	50.4	130	140
RH110		BT40-NPU13-150	1 - 13	50.4	150	160

* Chucking Length
 - NPU8 : 20mm
 - NPU13 : 28mm

DUAL CONTACT NC DRILL CHUCK

HSK

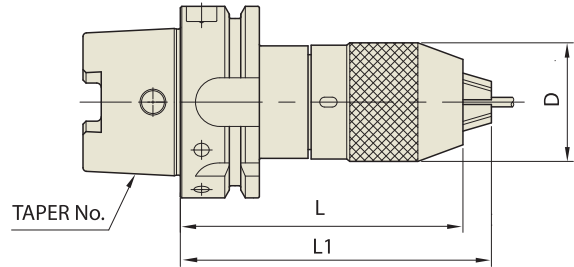

DIN 69893 - HSK	Taper Accuracy -	G Value -	RPM -	Coolant System -
--------------------	------------------------	--------------	----------	------------------------

DIN 69893/ISO 12164-1-HSK FORM A

Unit : mm

EDP No.	TAPER No.	MODEL No.	CAPACITY	D	L(Min.)	L1(Max.)
RQ100	63A	HSK63A-NPU8-125	0.3 - 8	36.5	125	130.7
RQ102		HSK63A-NPU13-150	1 - 13	50.4	150	160
RR100	100A	HSK100A-NPU8-130	0.3 - 8	36.5	130	135.7
RR102		HSK100A-NPU13-1510	1 - 13	50.4	150	160

STRAIGHT NC DRILL CHUCK

K

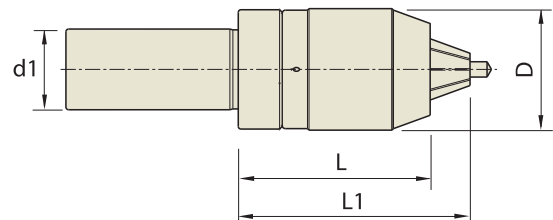

STRAIGHT-K

Unit : mm

EDP No.	TYPE	MODEL No.	RANGE	D	L(Min.)	L1(Max.)	d1
RS100	32	K32-NPU8-75	0.3 - 8	36.5	75	80.7	32.0
RS102		K32-NPU13-100	1 - 13	50.4	100	110	32.0
RS104	42	K42-NPU8-70	0.3 - 8	36.5	70	75.7	42.0
RS106		K42-NPU13-100	1 - 13	50.4	100	110	42.0



ROTARY TOOLING

JACOBS TAPER ARBOR



JACOBS TAPER ARBOR

CAT : ASME B5.50-2009

BT : JIS B6339/MAS 403

JACOBS TAPER ARBOR

CAT

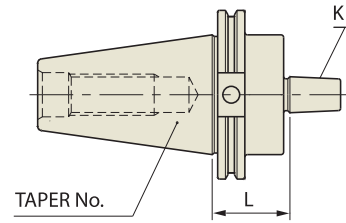

ASME B5.50 -CAT	Taper Accuracy AT3	G Value -	RPM -	Coolant System -
--------------------	------------------------------	--------------	----------	---------------------

ASME B5.50-2009-CAT

Unit : inch

EDP No.	TAPER No.	MODEL No.	K	L
GK042	40	CAT40-JTA1-1.50	#1	1.50
GK043		CAT40-JTA2-1.50	#2	1.50
GK044		CAT40-JTA3-1.50	#3	1.50
GK045		CAT40-JTA4-1.50	#4	1.50
GK046		CAT40-JTA6-1.50	#6	1.50
GK047		CAT40-JTA33-1.50	#33	1.50
GL042	50	CAT50-JTA1-1.50	#1	1.50
GL043		CAT50-JTA2-1.50	#2	1.50
GL044		CAT50-JTA3-1.50	#3	1.50
GL045		CAT50-JTA4-1.50	#4	1.50
GL046		CAT50-JTA6-1.50	#6	1.50
GL047		CAT50-JTA33-1.50	#33	1.50

JACOBS TAPER ARBOR

BT

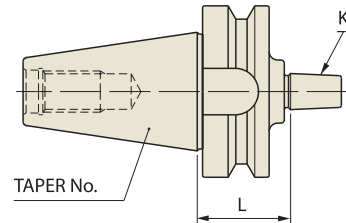

JIS B6339 -BT	Taper Accuracy AT3	G Value -	RPM -	Coolant System -
------------------	------------------------------	--------------	----------	---------------------

JIS B6339/MAS 403-BT

Unit : inch

EDP No.	TAPER No.	MODEL No.	K	L
GH042	40	BT40-JTA1-1.34	#1	1.34
GH043		BT40-JTA2-1.77	#2	1.77
GH044		BT40-JTA3-1.77	#3	1.77
GH045		BT40-JTA4-1.77	#4	1.77
GH046		BT40-JTA6-1.77	#6	1.77
GH047		BT40-JTA33-1.77	#33	1.77
GI042	50	BT50-JTA1-1.80	#1	1.80
GI043		BT50-JTA2-1.77	#2	1.77
GI044		BT50-JTA3-1.77	#3	1.77
GI045		BT50-JTA4-1.77	#4	1.77
GI046		BT50-JTA6-1.77	#6	1.77
GI047		BT50-JTA33-1.77	#33	1.77



ROTARY TOOLING

STUB ARBOR



STUB ARBOR

CAT : ASME B5.50-2009

BT : JIS B6339/MAS 403

ACCESSORY & PART

- NUT / KEY / SPACER

STUB ARBOR

CAT

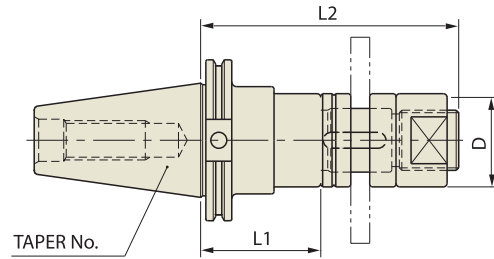

ASME B5.50 -CAT	Taper Accuracy AT3	G Value -	RPM -	Coolant System -
--------------------	-----------------------	--------------	----------	---------------------

ASME B5.50-2009-CAT

STANDARD

Unit: inch

EDP No.	TAPER No.	MODEL No.	CUTTER SIZE I.D	L1	D	L2
PK014	40	CAT40-STUB1"-4.00	1.000	4.00	1.56	6.25
PK017		CAT40-STUB1 1/4-4.00	1.250	4.00	1.87	6.50
PK021		CAT40-STUB1 1/2-4.00	1.500	4.00	2.12	6.75
PL014	50	CAT50-STUB1"-4.00	1.000	4.00	1.56	6.25
PL017		CAT50-STUB1 1/4-4.00	1.250	4.00	1.87	6.50
PL021		CAT50-STUB1 1/2-4.00	1.500	4.00	2.12	6.75

STUB ARBOR

BT

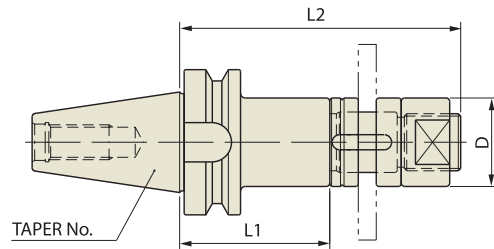

JIS B6339 -BT	Taper Accuracy AT3	G Value -	RPM -	Coolant System -
------------------	-----------------------	--------------	----------	---------------------

JIS B6339/MAS 403-BT

STANDARD

Unit: inch

EDP No.	TAPER No.	MODEL No.	CUTTER SIZE I.D	L1	D	L2
PH014	40	BT40-STUB1"-3.00	1.000	3.00	1.56	5.25
PH017		BT40-STUB1 1/4-3.00	1.250	3.00	1.87	5.50
PH021		BT40-STUB1 1/2-3.00	1.500	3.00	2.12	5.75
PI014	50	BT50-STUB1"-4.00	1.000	4.00	1.56	6.25
PI017		BT50-STUB1 1/4-4.00	1.250	4.00	1.87	6.50
PI021		BT50-STUB1 1/2-4.00	1.500	4.00	2.12	6.75

* Nuts / Key / Spacer for Stub Arbors on page 129.

NUT

Unit : inch

EDP No.	TYPE (M)	L	D	SERIES
ZZ041	UNF1-12	1.00	1.56	STUB1"
ZZ046	UNF11/4-12	1.25	1.87	STUB1 1/4
ZZ052	UNF11/2-12	1.50	2.12	STUB1 1/2

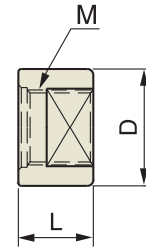

KEY

Unit : inch

EDP No.	SERIES	B
ZZ042	STUB1"	0.25
ZZ047	STUB1 1/4	0.312
ZZ054	STUB1 1/2	0.375

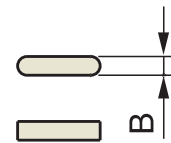

SPACER

Unit : inch

EDP No.	TYPE	H	D	d	SERIES
ZZ043	1/4-SPACER	0.25	1.56	1.00	STUB1"
ZZ044	3/8-SPACER	0.375	1.56	1.00	STUB1"
ZZ045	3/4-SPACER	0.75	1.56	1.00	STUB1"

EDP No.	TYPE	H	D	d	SERIES
ZZ048	1/4-SPACER	0.25	1.87	1.25	STUB1 1/4
ZZ049	3/8-SPACER	0.375	1.87	1.25	STUB1 1/4
ZZ050	3/4-SPACER	0.75	1.87	1.25	STUB1 1/4

EDP No.	TYPE	H	D	d	SERIES
ZZ037	1/4-SPACER	0.25	2.12	1.50	STUB1 1/2
ZZ038	3/8-SPACER	0.375	2.12	1.50	STUB1 1/2
ZZ039	3/4-SPACER	0.75	2.12	1.50	STUB1 1/2

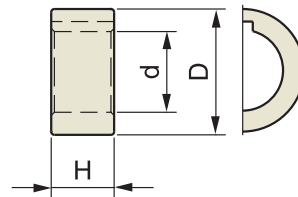

Rotary Tooling



**THE WORLD LEADER IN
THE TOOL HOLDER INDUSTRY**

-
- HYDRAULIC CHUCK
 - SHRINK FIT HOLDER
 - END MILL HOLDER & SIDE LOCK ARBOR
 - ER COLLET CHUCK
 - SK SLIM CHUCK
 - TG COLLET CHUCK
 - POWER MILLING CHUCK
 - MORSE TAPER ADAPTER
 - TAPPING CHUCK
 - SHELL MILL ARBOR
 - NC DRILL CHUCK
 - JACOBS TAPER ARBOR
 - STUB ARBOR
 - SLITTING SAW ARBOR
 - PULL STUD & TOOL CLAMP
-





ROTARY TOOLING

SLITTING SAW ARBOR

SLITTING SAW ARBOR

CAT : ASME B5.50-2009

BT : JIS B6339/MAS 403

ACCESSORY & PART

- CAP

SLITTING SAW ARBOR

CAT

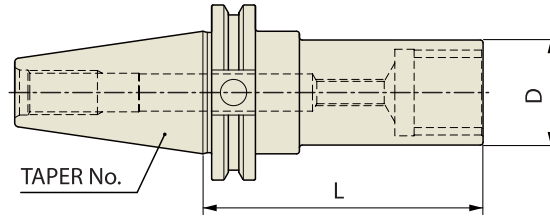

■ STANDARD

Unit : inch

EDP No.	TAPER No.	MODEL No.	COLLET SERIES	L	D
QK014	40	CAT40-SSA1"-4.00	1.000	4.00	1.50
QK017		CAT40-SSA1 1/4-4.00	1.250	4.00	2.00
QL014	50	CAT50-SSA1"-4.00	1.000	4.00	1.50
QL017		CAT50-SSA1 1/4-4.00	1.250	4.00	2.00

SLITTING SAW ARBOR

BT

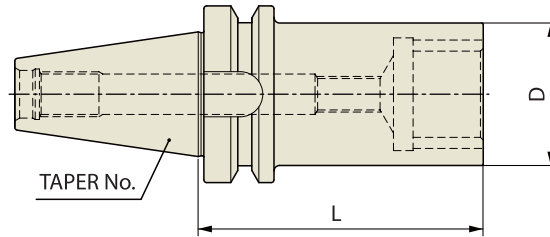

■ STANDARD

Unit : inch

EDP No.	TAPER No.	MODEL No.	COLLET SERIES	L	D
QH014	40	BT40-SSA1"-4.00	1.000	4.00	1.50
QH017		BT40-SSA 1 1/4-4.00	1.250	4.00	2.00

CAP

EDP No.	TYPE	L	D	d
ZZ051	SSA1"	1.02	1.50	1.00
ZZ053	SSA1 1/4	1.30	2.00	1.25

Unit : inch

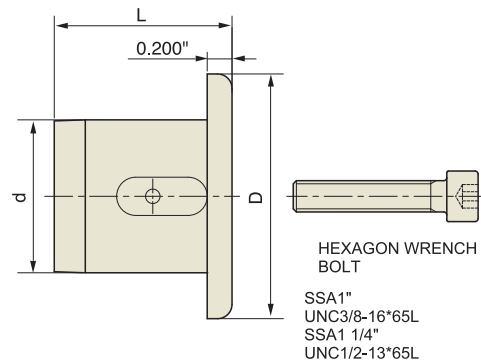

HEXAGON WRENCH BOLT

SSA1"
UNC3/8-16*65L
SSA1 1/4"
UNC1/2-13*65L



ROTARY TOOLING

PULL STUD & TOOL CLAMP



PULL STUD

TOOL CLAMP

COOLANT TUBE

PULL STUD

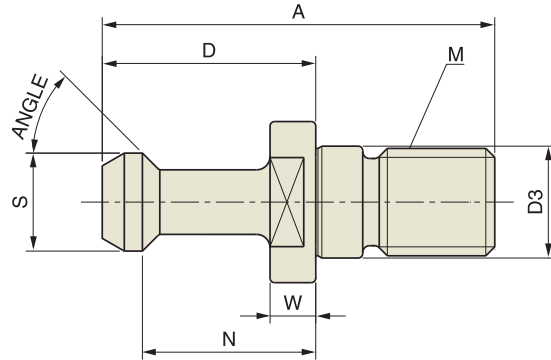

EDP NO.	MODEL No.	ANGLE	S	P	D3	A	N	D	W	M
SK661	CAT-40ANSI C	45°	0.740	0.490	0.490	1.500	0.440	0.640	0.120	5/8-11
SL661	CAT-50ANSI C	45°	1.140	0.820	0.820	2.300	0.700	1.000	0.200	1-8
SK561	CAT-40ANSI	45°	0.740	0.490	0.490	1.500	0.440	0.640	0.120	5/8-11
SL561	CAT-50ANSI	45°	1.140	0.820	0.820	2.300	0.700	1.000	0.200	1-8
SK761	CAT-40TYPE I	45°	0.590	0.394	0.512	2.250	0.990	1.266	0.120	5/8-11
SK762	CAT-40TYPE II	60°	0.590	0.394	0.512	2.250	0.990	1.266	0.120	5/8-11
SK763	CAT-40TYPE III	90°	0.590	0.394	0.512	2.250	0.990	1.266	0.120	5/8-11
SK861	CAT-40TYPE I C	45°	0.590	0.394	0.512	2.250	0.990	1.266	0.120	5/8-11
SK862	CAT-40TYPE II C	60°	0.590	0.394	0.512	2.250	0.990	1.266	0.120	5/8-11
SK863	CAT-40TYPE III C	90°	0.590	0.394	0.512	2.250	0.990	1.266	0.120	5/8-11
SL761	CAT-50TYPE I	45°	0.906	0.669	0.827	3.346	1.377	1.772	0.390	1-8
SL762	CAT-50TYPE II	60°	0.906	0.669	0.827	3.346	1.377	1.772	0.390	1-8
SL763	CAT-50TYPE III	90°	0.906	0.669	0.827	3.346	1.377	1.772	0.390	1-8
SL861	CAT-50TYPE I C	45°	0.906	0.669	0.827	3.346	1.377	1.772	0.390	1-8
SL862	CAT-50TYPE II C	60°	0.906	0.669	0.827	3.346	1.377	1.772	0.390	1-8
SL863	CAT-50TYPE III C	90°	0.906	0.669	0.827	3.346	1.377	1.772	0.390	1-8
SH061	BT-40PS1	45°	0.590	0.394	0.669	2.360	1.102	1.378	0.230	M16
SI061	BT-50PS5	45°	0.905	0.669	0.984	3.346	1.377	1.772	0.390	M24
SH062	BT-40PS2	60°	0.590	0.394	0.669	2.360	1.102	1.378	0.230	M16
SI062	BT-50PS6	60°	0.905	0.669	0.984	3.346	1.377	1.772	0.390	M24
SH063	BT-40PS8	90°	0.590	0.394	0.669	2.360	1.102	1.378	0.230	M16
SI063	BT-50PS0	90°	0.905	0.669	0.984	3.346	1.377	1.772	0.390	M24
SK161	CAT-40TYPE I	45°	0.590	0.394	0.512	2.250	0.990	1.266	0.236	5/8-11
SK162	CAT-40TYPE II	60°	0.590	0.394	0.512	2.250	0.990	1.266	0.236	5/8-11
SK163	CAT-40TYPE III	90°	0.590	0.394	0.512	2.250	0.990	1.266	0.236	5/8-11
SK261	CAT-40TYPE I C	45°	0.590	0.394	0.512	2.250	0.990	1.266	0.236	5/8-11
SK262	CAT-40TYPE II C	60°	0.590	0.394	0.512	2.250	0.990	1.266	0.236	5/8-11
SK263	CAT-40TYPE III C	90°	0.590	0.394	0.512	2.250	0.990	1.266	0.236	5/8-11

* Suffix "C" in MODEL No. is through coolant type.

* Improper selection of pull studs can cause serious damage and possible injury.
Please make sure the machine accepts the pull stud you select.

TOOL CLAMP

EDP No.	MODEL No.	SHANK FLANGE TYPE
RK099	TCT-40	CAT-40
RH099	TBT-40	BT-40
RL099	TCT-50	CAT-50
RM099	TBT-50	BT-50

* Available in all tapers.

Feature

- Access both ends of your tool holders simultaneously
- Minimizes tool holders handling
- Speeds up your operations
- Convenient



COOLANT TUBE

CT

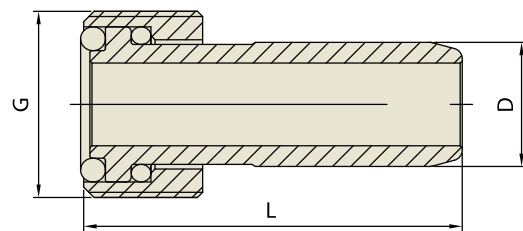

Unit: mm

EDP Code	TAPER No.	G	L	D
CT320	32A	M10x1.0	26	6
CT400	40A	M12x1.0	29.1	8
CT500	50A	M16x1.0	32.9	10
CT630	63A	M18x1.0	36.6	12
CT100	100A	M24x1.5	43.9	16

TECHNICAL INFORMATION

HYDRAULIC CHUCK



- **High precision T.I.R :**
 $\leq 0.00012''$ (Without Reduction Sleeve)

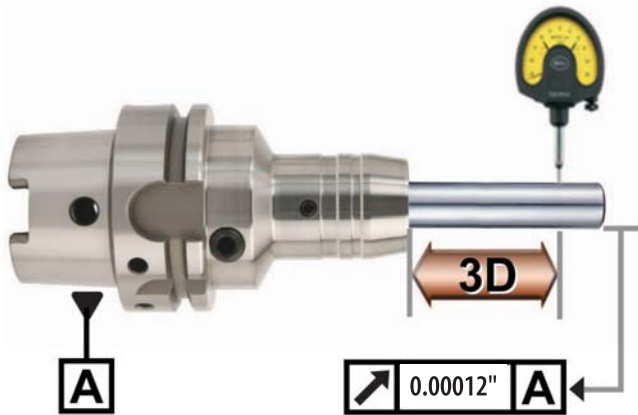

- Less than 0.00012" T.I.R
 => Suitable for high-speed precision machining

- **Flexible use of cutting tools by using reduction sleeves**

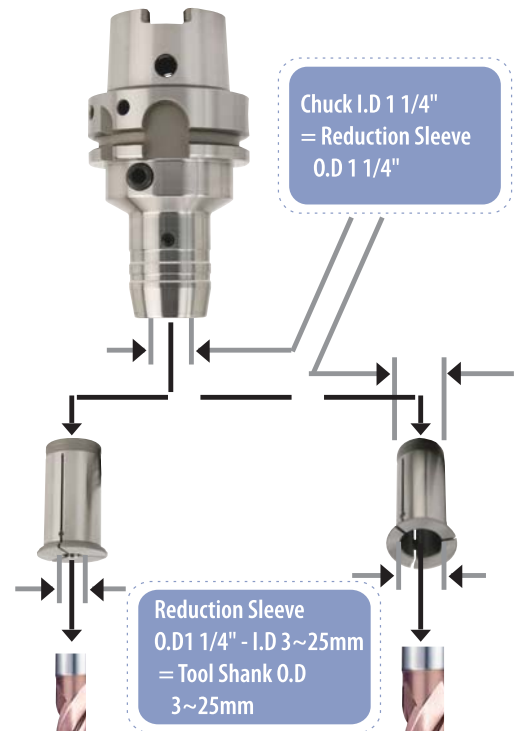

- **Easy Tool Change**

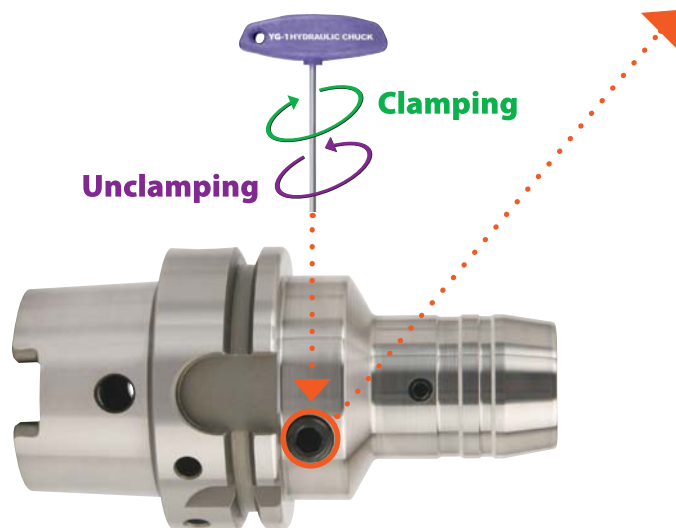

- Easy clamping and unclamping by use of T wrench
 => Reducing tool change time

CLAMPING SCREW

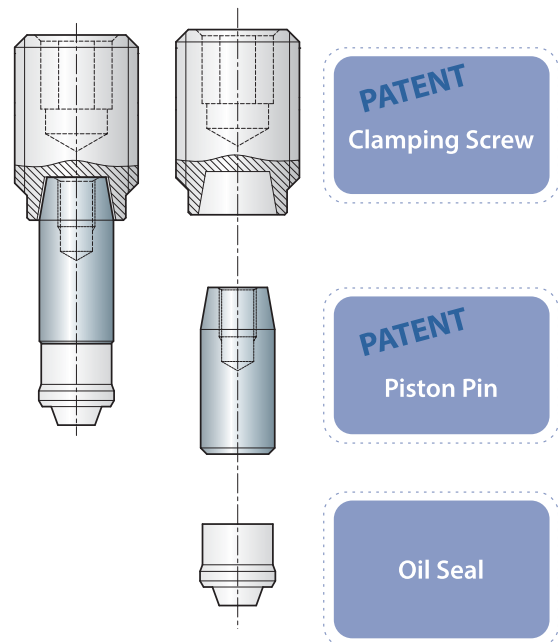

TECHNICAL INFORMATION

HYDRAULIC CHUCK



● Strong Torque Power

Hydraulic Chuck I.D(mm)	Tool Shank O.D(mm)	Applicable RPM	Minimum Clamping Depth (mm)		Min. Torque Power (Nm)	
			Slim	Power E Hydro	Slim	Power E Hydro
6	6	40,000	27		16	
8	8	40,000	27		23	
10	10	40,000	32		45	
12	12	40,000	27	41	90	110
14	14	40,000	37		110	
16	16	40,000	42		185	
18	18	40,000	42		240	
20	20	40,000	42	48	330	520
25	25	25,000	48		400	
32	32	25,000	55	57	650	900

- Tool Holder I.D Tolerance : H6
- Operating Temperature : 20~25 °C
- Maximum pressure of coolant oil : 80bar



● Test of Torque Power and Hydraulic Oil Leakage

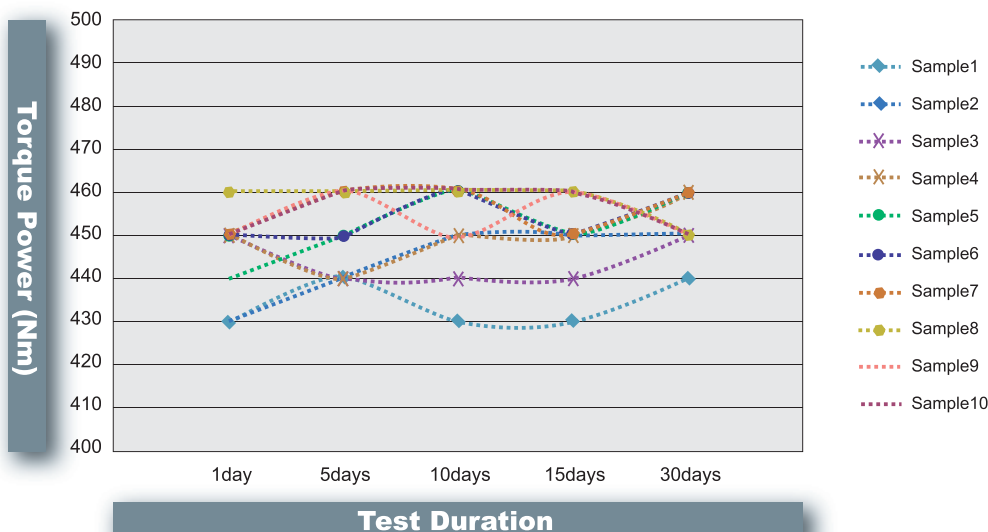

- Test Model : BT40AD/B-HC20-90
- No oil leakage for long period ⇒ Maintaining stable torque power

TECHNICAL INFORMATION

HYDRAULIC CHUCK



Radial Tool Length Pre-setting Type

- Easy to adjust pre-setting length of cutting tool (Saving time to pre-set cutting tool to one fifth compared with conventional Hydraulic Chuck)
- Precise adjustment of cutting tool length
- Designed to separate tool length adjustment screw from clamping screw

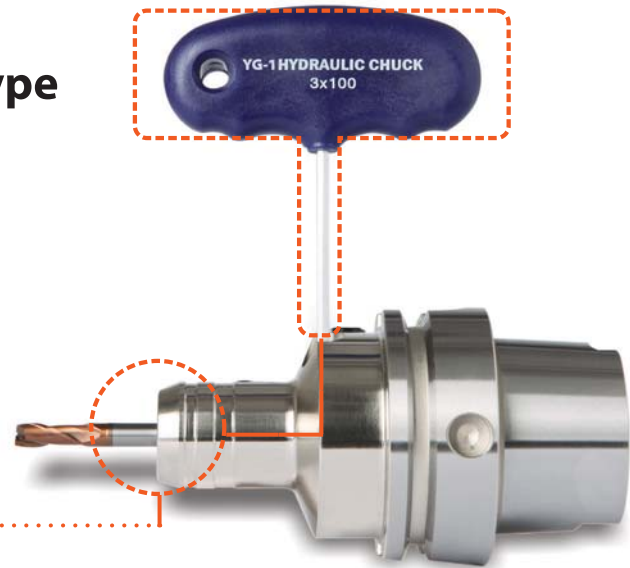

Adjustable range of cutting tool length : 0~0.394"

APPLICATION

Milling	High Speed Cutting	Fine Drilling
Reaming	Tapping & Thread Milling	Chamfering

TECHNICAL INFORMATION

SHRINK FIT HOLDER



- **High Precision I.D**
Run-out : $\leq 0.00012''$

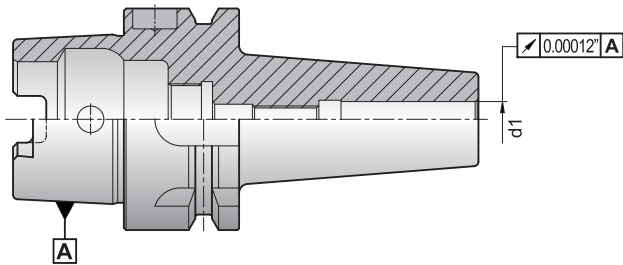

- Less than 0.00012" of Tool Holder accuracy at I.D

- **Strong and Consistent Torque Power**

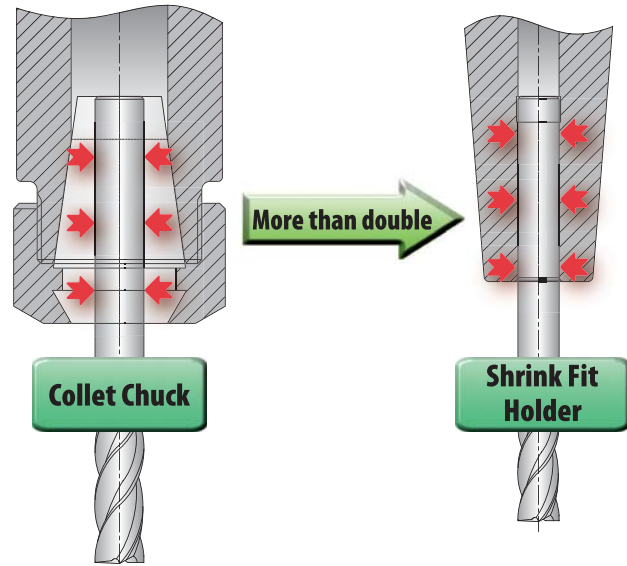

- Achieving strong torque power by integration of chuck and tool

- **Deep hole Machining**

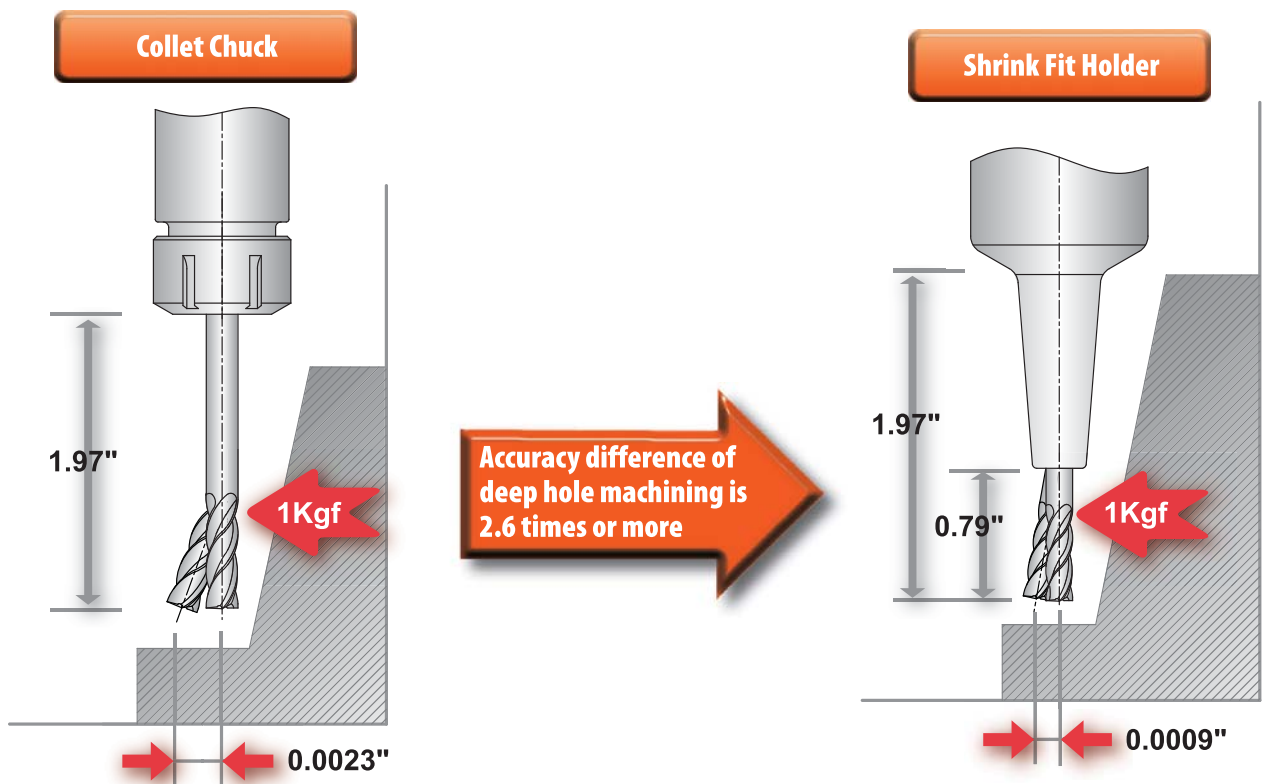

- Suitable for high-speed precision deep hole machining

TECHNICAL INFORMATION

SHRINK FIT HOLDER



APPLICATION

Rough Milling	Finish Milling	High Speed Cutting
Drilling	Reaming	Countersinking

● Shank Type of Cutting Tool

Straight shank



One weldon flat shaft type



- One Weldon flat shaft type tool is usable, but there is a possibility that the I.D of shrink fit holder may be deformed.

● Material of Cutting Tool

**CARBIDE
TOOL**

HSS TOOL

OK

NO



CLAMPING

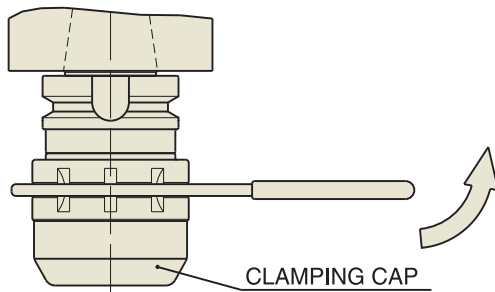

STRUCTURE

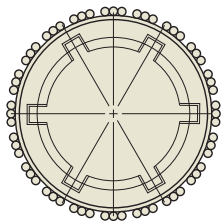

SPECIAL FEATURES

TOOL CLAMPING

For complete tool clamping, clamping cap should be fully turned up to the point where the bottom of clamping cap touches the flange of tool holder.

HOLDING POWER

Thicker body structure of clamping cap assures strong holding power maximum durability and smooth movement of needle bearings 300 kgf holding force.

ACCURACY

Slots on the inside of bore help prevent excessive oil and grime from building up between shank of end mill and inside of bore which increases accuracy and holding power.

DURABILITY

Special engineered steels and alloys are used in the bearing and stop seal to increase life and reduce maintenance.

TECHNICAL INFORMATION

T.I.R and TOLERANCE

● T.I.R (Total Indicated Run-out)

HYDRAULIC CHUCK

Concentric to 0.00012" T.I.R (at 3D)

SHRINK FIT HOLDER

Concentric to 0.00012" T.I.R (at I.D)

ER COLLET CHUCK

Concentric to 0.0002" T.I.R (at I.D)

END MILL HOLDER

Concentric to 0.0002" T.I.R (at I.D)

SLITTING SAW ARBOR

Face perpendicular to taper within 0.0002" T.I.R (at I.D)

STUB ARBOR

Face perpendicular to taper within 0.0002" T.I.R (at I.D)

SHELL MILL ARBOR

Face perpendicular to taper within 0.0001" T.I.R

Out diameter to taper within 0.0002" T.I.R

MORSE & JACOBS TAPER ARBOR

Concentric to 0.0003" T.I.R

* To put tool precisely on spindle center line for getting correct T.I.R.

● AT3 or better accuracy on all shank tapers

● Accurate and rigid tool holder mounting to spindle

● The bore diameter of all tool holders is controlled by H5 grade tolerance limit.

TAPER	AT3
#30	0.000078"
#40	0.00012"
#50	0.00016"

HIGH QUALITY PRODUCTS and ON TIME DELIVERY for WORLD-WIDE CUSTOMERS

Since 1982, YG-1 has been committed to quality, innovation and the unique customer experience.

Our performance and experience have granted YG-1 the global impression of one of the leading manufacturers of high quality cutting tool solutions. This global footprint expands over 75 countries, with international logistic centers, pledging to our customers to give the best service available today - and tomorrow.

EUROPE

 BELGIUM	 FINLAND	 ITALY	 PORTUGAL	 SLOVENIA	 THE NETHERLANDS
 CROATIA	 FRANCE	 LITHUANIA	 ROMANIA	 SPAIN	 TURKEY
 CZECH REPUBLIC	 GERMANY	 NORWAY	 RUSSIA	 SWEDEN	 UNITED KINGDOM
 DENMARK	 HUNGARY	 POLAND	 SERBIA	 SWITZERLAND	

ASIA PACIFIC

 AUSTRALIA	 INDONESIA	 KINGDOM OF SAUDI ARABIA	 SINGAPORE	 UNITED ARAB EMIRATES
 CHINA	 IRAN	 MALAYSIA	 SOUTH KOREA	 VIETNAM
 HONG KONG	 ISRAEL	 PAKISTAN	 TAIWAN	
 INDIA	 JAPAN	 PHILIPPINES	 THAILAND	

AMERICAS

 BRAZIL	 CANADA	 COLOMBIA	 MEXICO	 UNITED STATES
--	--	--	--	---

AFRICA

 EGYPT	 SOUTH AFRICA
---	--

 **YG-1 CO., LTD.**

* For the more information on sales network, please contact the head office as below;

YG-1 HEAD OFFICE

211, Sewolcheon-ro, Bupyeong-gu, Incheon, South Korea
Phone: +82-32-526-0909
E-mail: yg1@yg1.kr
www.yg1.kr

YG-1 USA

730 Corporate Woods Parkway, Vernon Hills, IL 60061 U.S.A.
Phone: 800-765-8665
Technical Assistance: 888-868-5988
www.yg1usa.com

Hydraulic Chuck
Shrink Fit Holder
End Mill Holder & Side Lock Arbor
ER Collet Chuck
SK Slim Chuck
TG Collet Chuck
Power Milling Chuck
Morse Taper Adapter
Tapping Chuck
Shell Mill Arbor
NC Drill Chuck
Jacobs Taper Arbor
Stub Arbor
Slitting Saw Arbor
Pull Stud & Tool Clamp

YG-1 CO., LTD.

YG-1 USA

730 Corporate Woods Parkway Vernon Hills, IL 60061 U.S.A.
 Phone: 800-765-8665
 Technical Assistance: 888-868-5988
<http://www.yg1usa.com>

HEAD OFFICE

211, Sewolcheon-ro, Bupyeong-gu, Incheon, South Korea
 Phone: +82-32-526-0909
<http://www.yg1.kr>
 E-mail: yg1@yg1.kr

Note The new address above has currently been updated since Korean new postal standard was valid from 2014.
 Be noticed that the physical Headquarter location is NOT changed.



Search 'YG-1' on social media outlets

Tool specifications are subject to change without prior notice.

YG1YUTH180713004

